

Split idler wheel 21 teeth (for chains series 815, 820, 831) - Part. C42
Ruota rinvio dentata in due metà per Z21 (per catene serie 815, 820, 831) - Part. C42

Application example
Esempio di applicazione

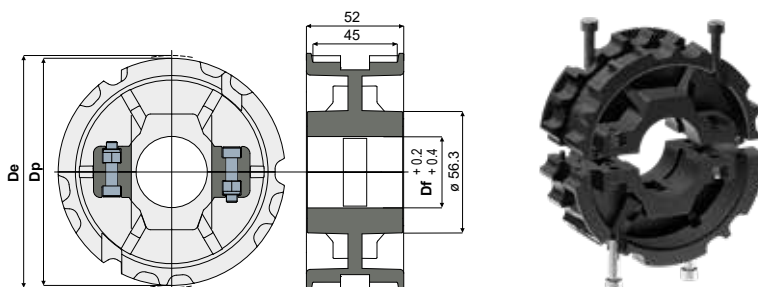
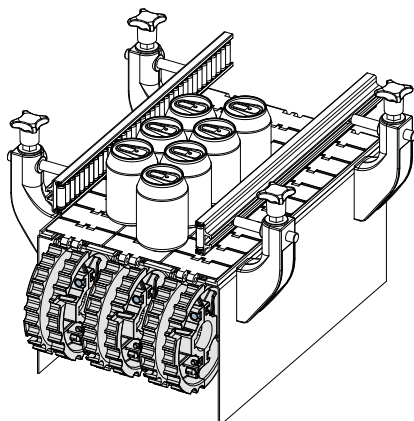

Type/Tipo	Code/Codice	Df (mm)	Dp (mm)	De (mm)
C42A	CPB00013	25	129,3	128
C42B	CPB00014	30	129,3	128
C42C	CPB00015	35	129,3	128
C42D	CPB00016	40	129,3	128

MATERIALS: Wheel made of polyamide black colour; screws made of stainless steel AISI 304, nuts in nickel plated brass.

MATERIALI: Ruota in poliammide colore nero; viti in acciaio inox AISI 304; dadi in ottone nichelato.

Split sprocket 21 teeth (for chains series 815, 820, 831) - Part. C43
Ruota di traino dentata in due metà per Z21 (for chains series 815, 820, 831) - Part. C43

Application example
Esempio di applicazione

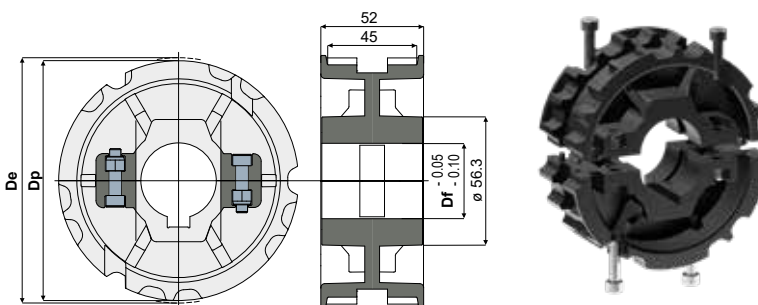
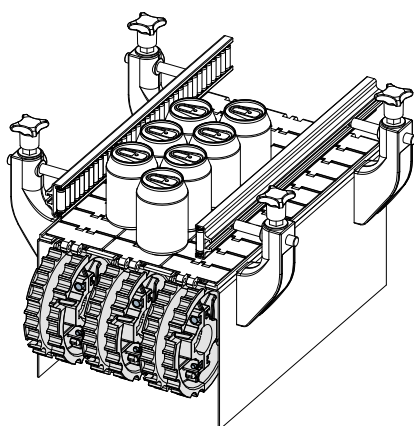

Type/Tipo	Code/Codice	Df (mm)	Dp (mm)	De (mm)
C43A	CPB00017	25	129,3	128
C43B	CPB00018	30	129,3	128
C43C	CPB00019	35	129,3	128
C43D	CPB00020	40	129,3	128

MATERIALS: Wheel made of polyamide black colour; screws made of stainless steel AISI 304, nuts in nickel plated brass.

MATERIALI: Ruota in poliammide colore nero; viti in acciaio inox AISI 304; dadi in ottone nichelato.

Split idler wheel 23 teeth (for chains series 815, 820, 831) - Part. C40
Ruota rinvio dentata in due metà per Z23 (per catene serie 815, 820, 831) - Part. C40

Application example
Esempio di applicazione

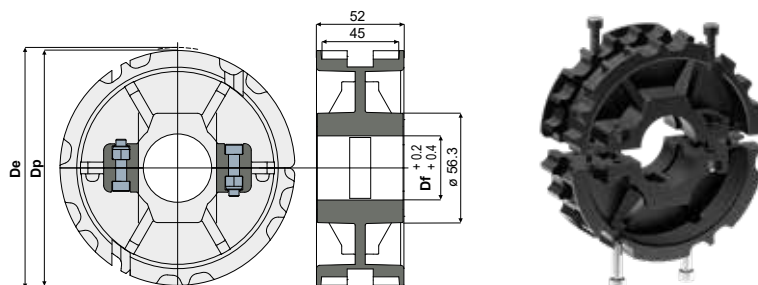
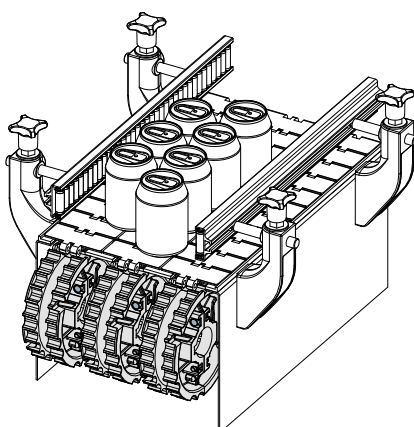

Type/Tipo	Code/Codice	Df (mm)	Dp (mm)	De (mm)
C40A	CPB00021	25	141,2	140
C40B	CPB00022	30	141,2	140
C40C	CPB00023	35	141,2	140
C40D	CPB00024	40	141,2	140

MATERIALS: Wheel made of polyamide black colour; screws made of stainless steel AISI 304, nuts in nickel plated brass.

MATERIALI: Ruota in poliammide colore nero; viti in acciaio inox AISI 304; dadi in ottone nichelato.