

Split sprocket 23 teeth (for chains series 815, 820, 831) - Part. C41

Ruota di traino dentata in due metà per Z23 (for chains series 815, 820, 831) - Part. C41

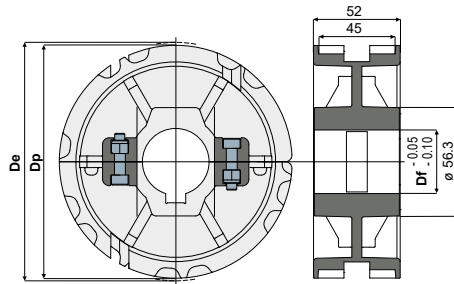

Type/Tipo	Code/Codice	Df (mm)	Dp (mm)	De (mm)
C41A	CPB00025	25	141,2	140
C41B	CPB00026	30	141,2	140
C41C	CPB00027	35	141,2	140
C41D	CPB00028	40	141,2	140

MATERIALS: Wheel made of polyamide black colour; screws made of stainless steel AISI 304, nuts in nickel plated brass.

MATERIALI: Ruota in poliammide colore nero; viti in acciaio inox AISI 304; dadi in ottone nichelato.

Application example
Esempio di applicazione

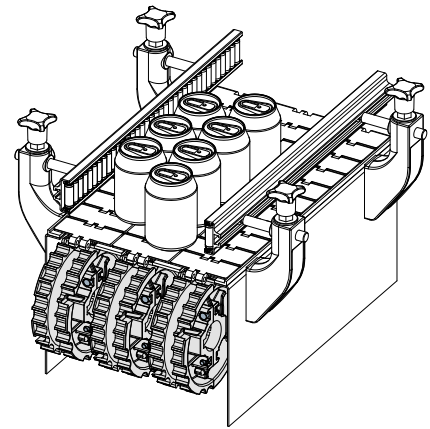

Split idler wheel 25 teeth (for chains series 815, 820, 831) - Part. C35

Ruota rinvio dentata in due metà per Z25 (for chains series 815, 820, 831) - Part. C35

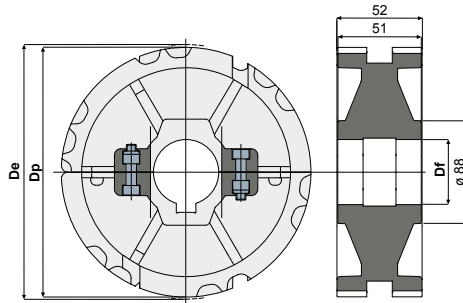

Type/Tipo	Code/Codice	Df (mm)	Dp (mm)	De (mm)
C35A	CPA00166	25	153,2	153
C35B	CPA00167	30	153,2	153
C35C	CPA00168	35	153,2	153
C35D	CPA00169	40	153,2	153

MATERIALS: Wheel made of polyamide black colour; screws made of stainless steel AISI 304, nuts in nickel plated brass.

MATERIALI: Ruota in poliammide colore nero; viti in acciaio inox AISI 304; dadi in ottone nichelato.

Application example
Esempio di applicazione

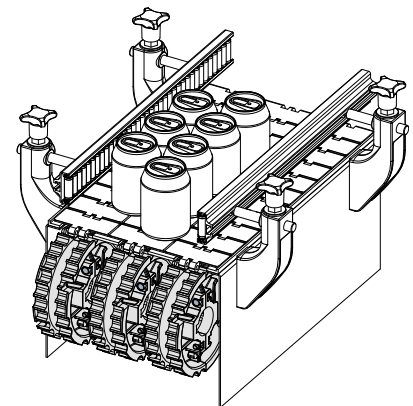

Split sprocket 25 teeth (for chains series 815, 820, 831) - Part. C23

Ruota di traino dentata in due metà per Z25 (for chains series 815, 820, 831) - Part. C23

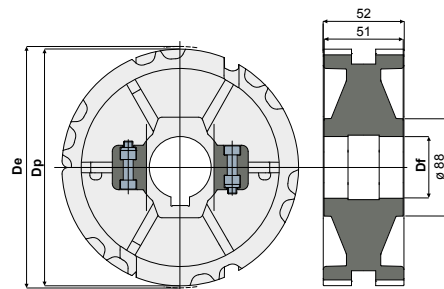

Type/Tipo	Code/Codice	Df (mm)	Dp (mm)	De (mm)
C23A	CPA00297	25	153,2	153
C23B	CPA00298	30	153,2	153
C23C	CPA00299	35	153,2	153
C23D	CPA00300	40	153,2	153

MATERIALS: Wheel made of polyamide black colour; screws made of stainless steel AISI 304, nuts in nickel plated brass.

MATERIALI: Ruota in poliammide colore nero; viti in acciaio inox AISI 304; dadi in ottone nichelato.

Application example
Esempio di applicazione

