

Split sprocket 12 teeth (for chains series 879, 879 Tab, 880 e 880 Tab) - Part. Q56

Ruota di traino dentata in due metà per Z12 (per catene serie 879, 879 Tab, 880 e 880 Tab) - Part. Q56

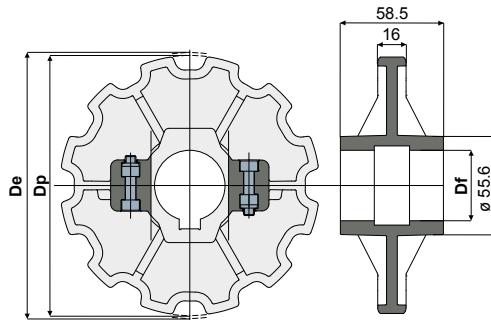

Application example
Esempio di applicazione

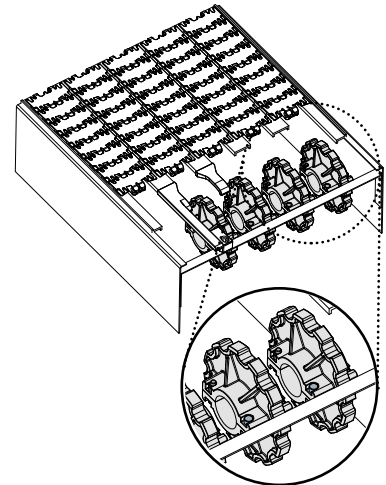

Type/Tipo	Code/Codice	Df (mm)	Dp (mm)	De (mm)
Q56A	CPA00313	25	147,2	147,4
Q56B	CPA00314	30	147,2	147,4
Q56C	CPA00315	35	147,2	147,4
Q56D	CPA00316	40	147,2	147,4

MATERIALS: Wheel made of reinforced polyamide black colour; screws made of stainless steel AISI 304, nuts in nickel plated brass.

MATERIALI: Ruota in poliammide rinforzata colore nero; viti in acciaio inox AISI 304; dadi in ottone nichelato.

Split idler wheel 12 teeth (for chains series 882, 882 Tab) - Part. Q72

Ruota rinvio dentata in due metà per Z12 (per catene serie 882, 882 Tab) - Part. Q72

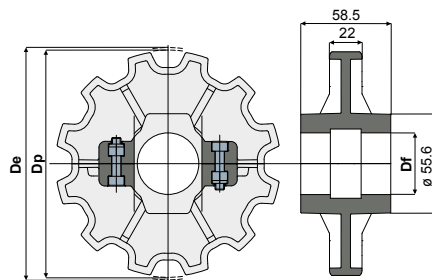

Application example
Esempio di applicazione

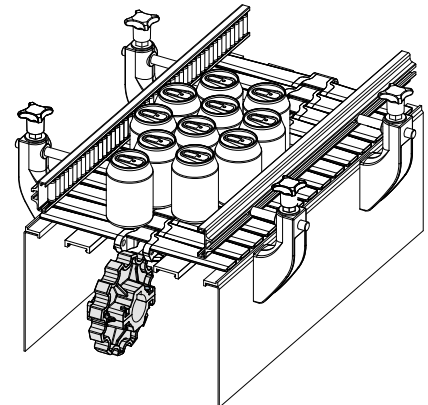

Type/Tipo	Code/Codice	Df (mm)	Dp (mm)	De (mm)
Q72A	CPA00284	25	147,2	149
Q72B	CPA00285	30	147,2	149
Q72C	CPA00286	35	147,2	149
Q72D	CPA00287	40	147,2	149

MATERIALS: Wheel made of polyamide black colour; screws made of stainless steel AISI 304, nuts in nickel plated brass.

MATERIALI: Ruota in poliammide colore nero; viti in acciaio inox AISI 304; dadi in ottone nichelato.

Split sprocket 12 teeth (for chains series 882, 882 Tab) - Part. Q73

Ruota di traino dentata in due metà per Z12 (per catene serie 882, 882 Tab) - Part. Q73

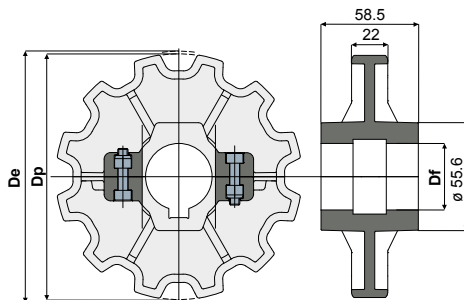

Application example
Esempio di applicazione

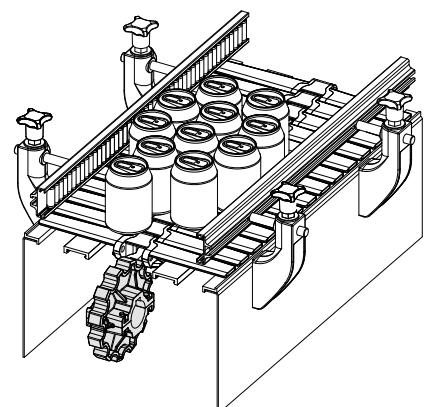

Type/Tipo	Code/Codice	Df (mm)	Dp (mm)	De (mm)
Q73A	CPA00288	25	147,2	149
Q73B	CPA00289	30	147,2	149
Q73C	CPA00290	35	147,2	149
Q73D	CPA00291	40	147,2	149

MATERIALS: Wheel made of reinforced polyamide black colour; screws made of stainless steel AISI 304, nuts in nickel plated brass.

MATERIALI: Ruota in poliammide rinforzata colore nero; viti in acciaio inox AISI 304; dadi in ottone nichelato.