

**BLU 弹性组件 – 型号 BL-Z: 具镀锌钢制弹簧 – 型号 BL-X: 具不锈钢弹簧**

**BLU elastic elements - Type BL-Z: with spring in galvanized steel – Type BL-X: with spring in stainless steel**

BLU 完全由塑性材料制成，具不锈钢螺钉。内部的弹簧可为镀锌钢或不锈钢材质。最高工作温度为+80°C。所有的主体都配有预加负荷系统。行程为 40 mm。

BLU is completely built in plastic with screws in stainless steel. The inside spring can be in galvanized or stainless steel. The maximum operating temperature is +80°C. All the bodies are supplied with preloading system. The stroke is 40 mm.

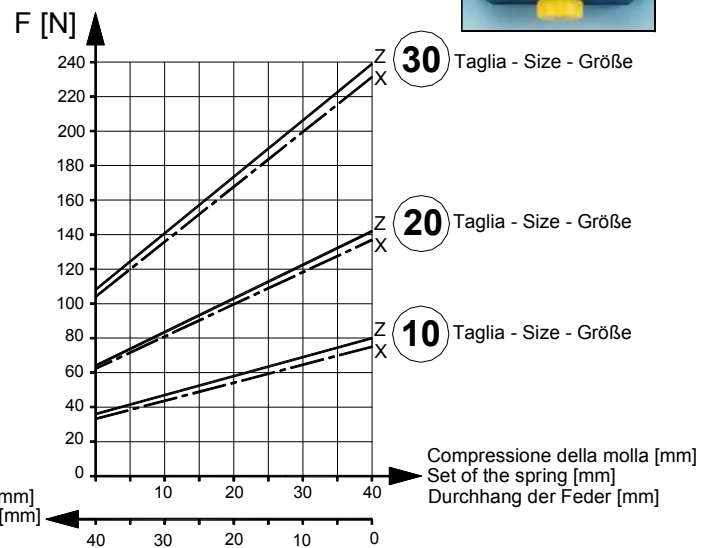
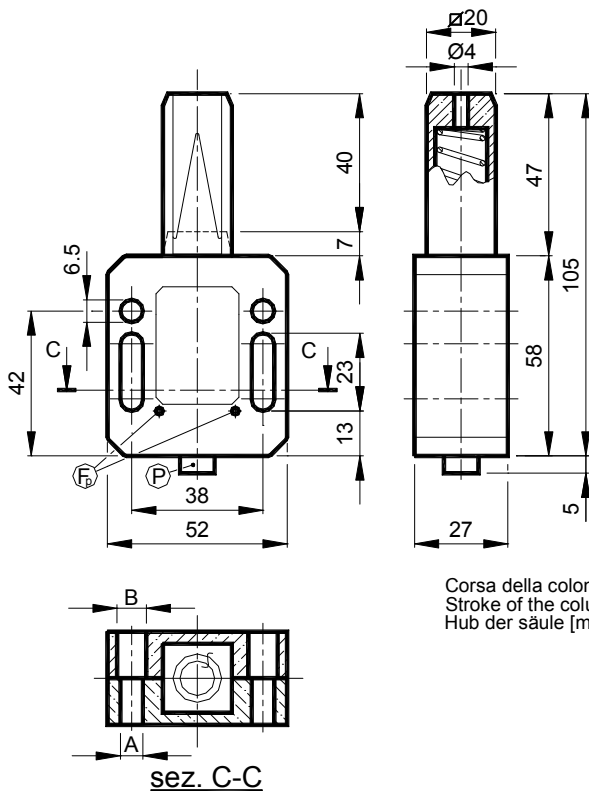









**Diagramma di carico  
Loading diagram  
Ladungsdiagramm**

ⓕ = 预加负荷孔 – Preloading hole

ⓐ = 预加负荷用桩销 – Preloading pin

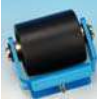
具镀锌钢制弹簧 With spring in galvanized steel		重量: 0,1 Kg Weight: 0,1 Kg			具不锈钢制弹簧 With spring in stainless steel		重量: 0.1 Kg Weight: 0,1 Kg
型号 Type	编号 N°	A	B	Newton	型号 Type	编号 N°	Newton
BL 10-6 Z	BL010010	6.5	6.5	36-79	BL 10-6 X	BL010110	35-77
BL 10-8 Z	BL010013	8.5	8.5	36-79	BL 10-8 X	BL010113	35-77
BL 10-6/8 Z	BL010016	6.5	8.5	36-79	BL 10-6/8 X	BL010116	35-77
BL 20-6 Z	BL010020	6.5	6.5	64-142	BL 20-6 X	BL010120	63-139
BL 20-8 Z	BL010023	8.5	8.5	64-142	BL 20-8 X	BL010123	63-139
BL 20-6/8 Z	BL010026	6.5	8.5	64-142	BL 20-6/8 X	BL010126	63-139
BL 30-6 Z	BL010030	6.5	6.5	108-239	BL 30-6 X	BL010130	105-233
BL 30-8 Z	BL010033	8.5	8.5	108-239	BL 30-8 X	BL010133	105-233
BL 30-6/8 Z	BL010036	6.5	8.5	108-239	BL 30-6/8 X	BL010136	105-233

配套元件选择列表 / Choose table KIT

链条 - Chain (DIN 8187)		型号 - Type				尺寸 - Size	型号 - Type					最高皮带宽度 [mm] Max belt width [mm]
ISO	节距 Pitch	VF 	FR 	FC 	FN 		FP 	FU 	FPX 	FUX 	FG 	
		页数 16 Page	页数 17 Page	页数 18 Page	页数 19 Page		页数 20 Page	页数 20 Page	页数 21 Page	页数 21 Page	页数 22 Page	
04-B1	6 mm	VF 10-AU				10					FG A	15
04-B1	6 mm	VF 10-AS				10	FP 1	FU 1	FPX 1	FUX 1		30
05-B1	8 mm	VF 10-OU				10						
05-B1	8 mm	VF 10-OS	FR 10-OS			10						
06-B1	3/8"x7/32"	VF 10-1U				10						
06-B1	3/8"x7/32"	VF 10-1S	FR 10-1S	FC 10-1S		10						
06-B1	3/8"x7/32"	VF 20-1U				20					FG A	15
06-B1	3/8"x7/32"	VF 20-1S	FR 20-1S	FC 20-1S	FN 20-1S	20	FP 1	FU 1	FPX 1	FUX 1		30
06-B1	3/8"x7/32"				FN 30-1S	30						
08-B1	1/2"x5/16"	VF 20-2S	FR 20-2S	FC 20-2S		20					FG B	25
08-B1	1/2"x5/16"	VF 30-2S	FR 30-2S	FC 30-2S	FN 30-2S	30					FG B	25
10-B1	5/8"x3/8"	VF 20-3S	FR 20-3S	FC 20-3S		20	FP 2/3	FU 2/3	FPX 2/3	FUX 2/3		40
10-B1	5/8"x3/8"	VF 30-3S	FR 30-3S	FC 30-3S	FN 30-3S	30	FP 2/3	FU 2/3	FPX 2/3	FUX 2/3		40
12-B1	3/4"x7/16"	VF 30-4S	FR 30-4S			30					FG C	35
05-B2	8 mm	VF 10-0D	FR 10-0D			10						
06-B2	3/8"x7/32"	VF 10-1D	FR 10-1D			10						
06-B2	3/8"x7/32"	VF 20-1D	FR 20-1D			20						
06-B2	3/8"x7/32"				FN 30-1D	30						
08-B2	1/2"x5/16"	VF 20-2D	FR 20-2D			20						
08-B2	1/2"x5/16"	VF 30-2D	FR 30-2D			30						
10-B2	5/8"x3/8"	VF 30-3D				30						
05-B3	8 mm	VF 20-0T				20						
05-B3	8 mm	VF 30-0T				30						
06-B3	3/8"x7/32"	VF 20-1T				30						
06-B3	3/8"x7/32"	VF 30-1T	FR 30-1T			30						

尺寸 SIZE	<b>10:</b>	Z: 36 - 79 X: 35 - 77	N
尺寸 SIZE	<b>20:</b>	Z: 64 - 142 X: 63 - 139	N
尺寸 SIZE	<b>30:</b>	Z: 108 - 239 X: 105 - 233	N

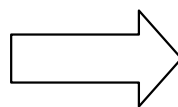

  
 页数  
Page  
13