

获专利 - PATENTED

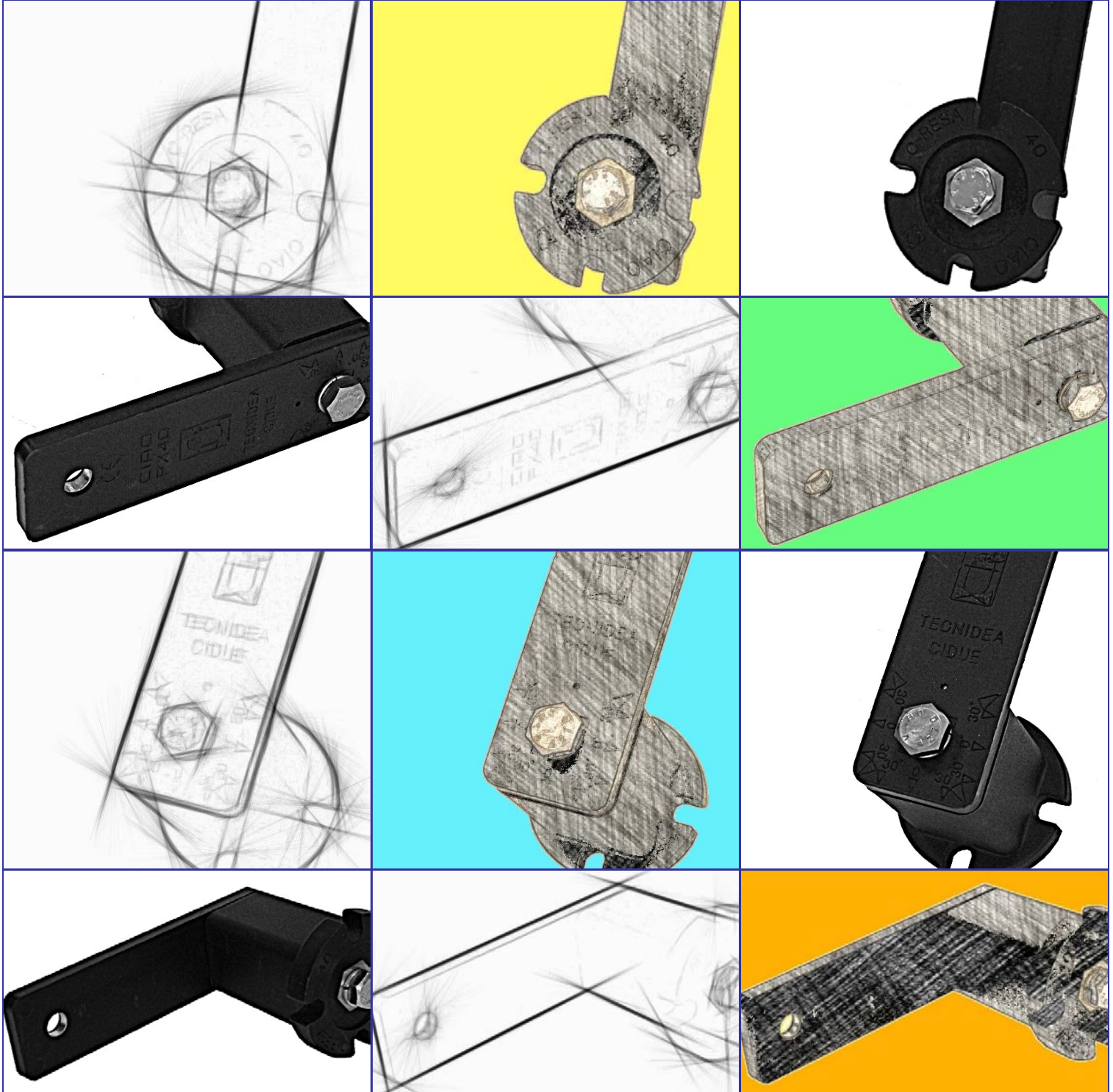

TECNIDEA CIDUE
泰尼达 S.r.l.



PX 塑料张紧装置 / PX Plastic tensioners

PX 张紧装置最适合在潮湿或腐蚀环境中工作。 / The PX tighteners are suitable to work in wet or corrosive places.

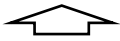
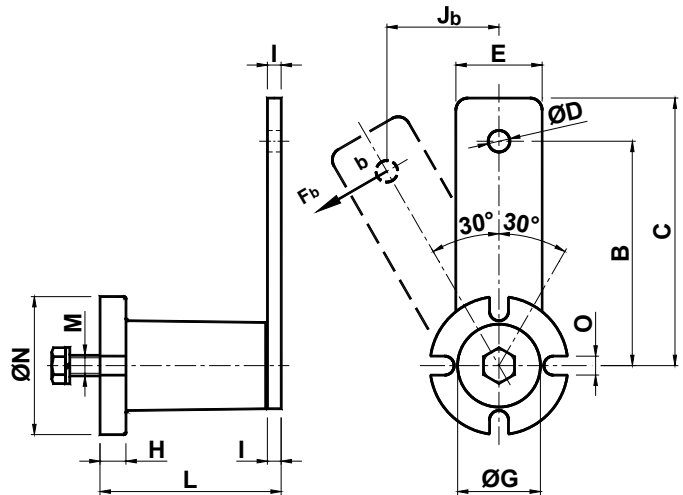

| 型号 Type | 编号 n° | B | F _b | C | ØD | E | ØG | H | I | L | M | ØN | O | R | 重量 Weight [Kg] | 编号 n° | 型号 Type |
|------------|----------|-----|----------------|-------|------|----|----|----|----|-------------------------------------|---------|----|----|------|-------------------|----------|------------|
| PX 10 | RE010910 | 80 | 85 | 90 | 8.5 | 24 | 20 | 6 | 7 | 52 ^{+1.5} _{-0.5} | M 6x 20 | 40 | 7 | 7.5 | 0.10 | RE010911 | PX 10 R |
| PX 20 | RE010920 | 100 | 136 | 112.5 | 10.5 | 30 | 30 | 8 | 8 | 66 ^{+1.5} _{-0.5} | M 8x 25 | 50 | 9 | 9.2 | 0.20 | RE010921 | PX 20 R |
| PX 30 | RE010930 | 100 | 340 | 115 | 10.5 | 36 | 35 | 10 | 8 | 79 ^{+1.5} _{-0.5} | M10x 30 | 60 | 9 | 10.5 | 0.26 | RE010931 | PX 30 R |
| PX 40 | RE010940 | 130 | 790 | 155 | 12.5 | 50 | 48 | 15 | 10 | 108 ^{+2.0} _{-0.5} | M12x 40 | 80 | 11 | 10.5 | 0.72 | RE010941 | PX 40 R |

F_b: 配件在孔 b 内安置时由张紧装置所施加的力量。 / Force made by the tensioner with the Kit positioned in the b hole



PX-R 塑料张紧装置 / PX-R plastic tensioners

PX-R 张紧装置最适合在潮湿或腐蚀环境中工作。PX-R 型具一个另加的加强螺钉，建议在存在与手柄操作平面垂直力量的情况下使用。 / The PX-R tighteners are suitable to work in wet or corrosive places. The PX-R type has an additional reinforcing screw, and it is advised in the case there are forces that are orthogonal with respect to the operating record of the lever.

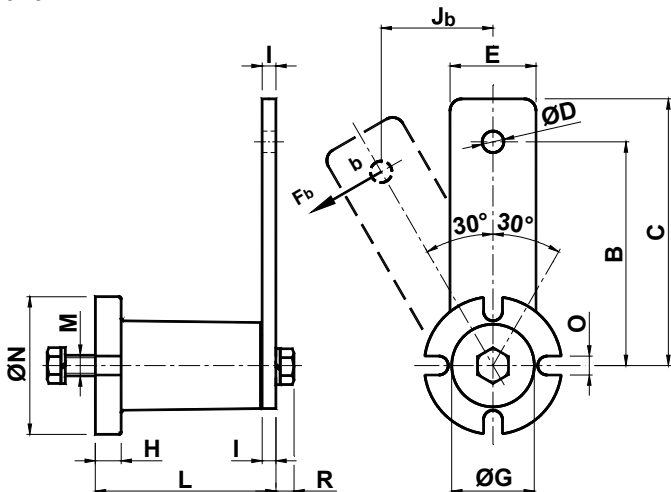

张紧装置PX和PX-R采用塑性材料制成，具金属内置物，适合在潮湿或腐蚀环境中工作。在两个方向可接受的最高扭转角度为30°。所有的PX和PX-R均配备不锈钢螺钉螺栓。

The PX and PX-R tighteners are made of plastic material with metal inserts and they are suitable to work in wet or corrosive places. The maximum acceptable rotation angle is of 30° in both the directions. All the PX and PX-R are delivered with Inox bolts and screws.

CEBX 塑料张紧装置 / CEBX Plastic tensioners

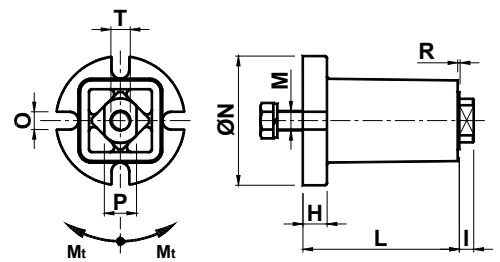

| 型号 Type | 编号 n° | M _t [Nm] | H | I | L | M | ØN | O | P | R | T | V | 重量 Weight [Kg] |
|------------|----------|------------------------|----|---|----|--------|----|----|------|---|-----|-----|----------------------|
| CEBX 10 | RE010990 | 0 ÷ 6.8 | 6 | 5 | 45 | M 6x20 | 40 | 7 | 9.5 | 1 | M 8 | M 4 | 0.10 |
| CEBX 20 | RE010991 | 0 ÷ 13.6 | 8 | 5 | 57 | M 8x25 | 50 | 9 | 12 | 1 | M10 | M 6 | 0.15 |
| CEBX 30 | RE010992 | 0 ÷ 34.0 | 10 | 7 | 70 | M10x30 | 60 | 9 | 14.5 | 1 | M10 | M 6 | 0.20 |
| CEBX 40 | RE010993 | 0 ÷ 103.0 | 15 | 9 | 97 | M12x40 | 80 | 11 | 20 | 1 | M12 | M 8 | 0.60 |

M_t: 扭转 30°所产生的扭矩; 以 Nm 表示。

M_t: developed torque with a rotation of 30°; in Nm.

CEBX 张紧装置的主体为塑性材料，中心轴和螺钉螺栓为不锈钢制。

这些产品可用于用户特殊应用中的基础配件或与在本产品目录中所展示的其他附件配合使用。适合在潮湿或腐蚀环境中工作。

The CEBX tensioners have the body of plastic material while the central pin, the bolts and screws are made of stainless steel.

These products act as basic elements for specific applications of the customer or together with the other accessories shown in this catalogue and they are suitable to work in wet or corrosive places.

CEPX 塑料张紧装置 / CEPX Plastic tensioners

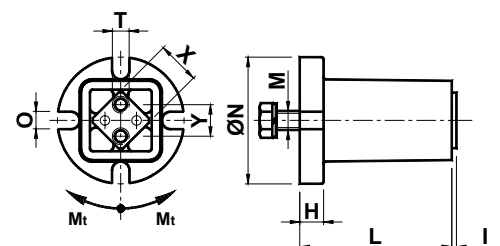

| 型号 Type | 编号 n° | M _t [Nm] | H | I | L | M | ØN | O | T | X | Y | V | 重量 Weight [Kg] |
|------------|----------|------------------------|----|---|----|--------|----|----|-----|----|----|-----|----------------------|
| CEPX 20 | RE011005 | 0 ÷ 13.6 | 8 | 1 | 56 | M 8x25 | 50 | 9 | M 6 | 15 | 10 | M 6 | 0.10 |
| CEPX 30 | RE011006 | 0 ÷ 34.0 | 10 | 1 | 69 | M10x30 | 60 | 9 | M 6 | 18 | 12 | M 6 | 0.15 |
| CEPX 40 | RE011007 | 0 ÷ 103.0 | 15 | 1 | 96 | M12x40 | 80 | 11 | M10 | 27 | 20 | M 8 | 0.40 |

M_t: 扭转 30°所产生的扭矩; 以 Nm 表示。

M_t: developed torque with a rotation of 30°; in Nm.

CEPX 张紧装置的主体为塑性材料，中心轴为铝制。螺钉螺栓为不锈钢。



这些产品可用于用户特殊应用中的基础配件或与在本产品目录中所展示的其他附件配合使用。适合在潮湿或腐蚀环境中工作。

The CEPX tensioners have the body of plastic material while the central pin is made of aluminium. The bolts and screws are in stainless steel. These products act as basic elements for specific applications of the customer or together with the other accessories shown in this catalogue and they are suitable to work in wet or corrosive places.

塑料张紧装置用附件 / Accessories for plastic tensioners

  泰尼达 S.r.l. 的塑料张紧装置可与用于链条和皮带的无数配套元件配合使用。

下表列出配件和张紧装置的所有可能配合方式。所有配套元件均配有不锈钢螺钉螺栓。配套元件也可不与弹性组件配合，而作为手动张紧装置或传动组使用。

 The  泰尼达 S.r.l. plastic tighteners can be used together with many Kits for chains and belts. The lower table shows all the possible combinations between Kit and tensioners. All the kits have stainless steel belts and screws. The kits can be used also without the elastic elements as manual tighteners or as return pinion unit.

| | Size | 链条 Chain | | 链条用配套元件 | | | | | | 皮带用配套元件 | | L _{max} |
|--------------|------|-------------|------------|-----------|-----------|-----------|-----------|-----------|-----------|---------|---------|------------------|
| | | ISO | 尺寸 / Size | XVR | XOV | XRO | XZN | AZN | XZK | XRP | XRU | |
| 单 SIMPLEX | 10 | 05-B1 | 8mm | XVR 10-0S | | XRO 10-0S | | | | XRP 1 | XRU 1 | 30 |
| | 10 | 06-B1 | 3/8"x7/32" | XVR 10-1S | XOV 10-1S | XRO 10-1S | | | | | | |
| | 20 | 06-B1 | 3/8"x7/32" | | | | XZN 20-1S | AZN 20-1S | XZK 20-1S | | | |
| | 30 | 06-B1 | 3/8"x7/32" | | | | XZN 30-1S | AZN 30-1S | XZK 30-1S | | | |
| | 20 | 08-B1 | 1/2"x5/16" | XVR 20-2S | XOV 20-2S | XRO 20-2S | | | | XRP 2/3 | XRU 2/3 | 40 |
| | 30 | 08-B1 | 1/2"x5/16" | XVR 30-2S | XOV 30-2S | XRO 30-2S | XZN 30-2S | AZN 30-2S | XZK 30-2S | XRP 2/3 | XRU 2/3 | 40 |
| | 30 | 10-B1 | 5/8"x3/8" | XVR 30-3S | XOV 30-3S | XRO 30-3S | XZN 30-3S | AZN 30-3S | | | | |
| | 40 | 10-B1 | 5/8"x3/8" | | | | XZN 40-3S | AZN 40-3S | XZK 40-3S | XRP 4 | XRU 4 | 55 |
| | 30 | 12-B1 | 3/4"x7/16" | XVR 30-4S | XOV 30-4S | XRO 30-4S | | | | | | |
| | 40 | 12-B1 | 3/4"x7/16" | XVR 40-4S | XOV 40-4S | XRO 40-4S | | | XZK 40-4S | XRP 4 | XRU 4 | 55 |
| | 40 | 16-B1 | 1"x17.02mm | XVR 40-5S | | XRO 40-5S | | | XZK 40-5S | | | |
| 双 DUPLIX | 10 | 05-B2 | 8mm | XVR 10-0D | | XRO 10-0D | | | | | | |
| | 10 | 06-B2 | 3/8"x7/32" | XVR 10-1D | XOV 10-1D | XRO 10-1D | | | | | | |
| | 20 | 06-B2 | 3/8"x7/32" | | | | | | XZK 20-1D | | | |
| | 30 | 06-B2 | 3/8"x7/32" | | | | | | XZK 30-1D | | | |
| | 20 | 08-B2 | 1/2"x5/16" | XVR 20-2D | XOV 20-2D | XRO 20-2D | | | | | | |
| | 30 | 08-B2 | 1/2"x5/16" | XVR 30-2D | XOV 30-2D | XRO 30-2D | | | XZK 30-2D | | | |
| | 30 | 10-B2 | 5/8"x3/8" | XVR 30-3D | XOV 30-3D | XRO 30-3D | | | | | | |
| | 40 | 10-B2 | 5/8"x3/8" | | | | | | XZK 40-3D | | | |
| | 30 | 12-B2 | 3/4"x7/16" | XVR 30-4D | XOV 30-4D | XRO 30-4D | | | | | | |
| | 40 | 12-B2 | 3/4"x7/16" | XVR 40-4D | XOV 40-4D | XRO 40-4D | | | XZK 40-4D | | | |
| | 40 | 16-B2 | 1"x17.02mm | XVR 40-5D | | XRO 40-5D | | | XZK 40-5D | | | |
| 三 TRIPLEX | 20 | 06-B3 | 3/8"x7/32" | XVR 20-1T | XOV 20-1T | XRO 20-1T | | | | | | |
| | 30 | 06-B3 | 3/8"x7/32" | | | | | | XZK 30-1T | | | |
| | 30 | 08-B3 | 1/2"x5/16" | XVR 30-2T | XOV 30-2T | XRO 30-2T | | | | | | |
| | 40 | 08-B3 | 1/2"x5/16" | | | | | | XZK 40-2T | | | |
| | 40 | 10-B3 | 5/8"x3/8" | XVR 40-3T | XOV 40-3T | XRO 40-3T | | | XZK 40-3T | | | |
| | 40 | 12-B3 | 3/4"x7/16" | XVR 40-4T | XOV 40-4T | XRO 40-4T | | | XZK 40-4T | | | |
| | 40 | 16-B3 | 1"x17.02mm | XVR 40-5T | | XRO 40-5T | | | | | | |

L_{max}: 皮带最高宽度 / maximum belt wideness

S: 单配件 / simplex kit

D: 双配件 / duplex kit

T: 三配件 / triplex kit

附件 型号 XVR / XVR accessories



 具高分子密度聚乙烯半圆形XVR滑块，适用于以经济的方式对速度不超过0.35m/s的单排、双排、三排链条进行张紧，工作温度低于 80°C。这个型号的滑块尤其适用于靠近链轮的安装和低轴距，或者存在足够的弧度半径。所供应配件包括所有的不锈钢螺钉螺栓。

 *XVR semi-circular sliding block in polyethylene with an high molecular density, suitable to tension in a cheaper way simplex, duplex or triplex chains which have a speed not higher than 0,35m/s and operating temperatures lower than 80°C.*

This type of sliding block is particularly suitable for installations close to the pinion and for reduced interaxis, or when there is an adequate radius of curvature. The kits are delivered complete with stainless steel bolts and screws.

| 型号 Type | S 编号 n° | D 编号 n° | T 编号 n° | 链条 Chain | 尺寸 Size  | 尺寸 | | | | | | | | | | | 重量 Weight [Kg] | | |
|------------|------------|------------|------------|-------------|---|----|----|-----|------|------|------|----|----|-----|-----|------|----------------|------|--|
| | | | | | | A | B | C | D | E | F | G | H | L | M | S | D | T | |
| XVR 10-0 | RE011975 | RE011995 | | 8mm | 10 | 45 | 45 | | 10 | 12 | | 10 | 35 | 2.5 | M 8 | 0.09 | 0.10 | | |
| XVR 10-1 | RE011976 | RE011996 | | 3/8"x7/32" | 10 | 45 | 45 | | 10 | 18 | | 10 | 35 | 5 | M 8 | 0.09 | 0.10 | | |
| XVR 20-1 | | | RE012015 | 3/8"x7/32" | 20 | | | 45 | | | 25 | 10 | 35 | 5 | M10 | | | 0.12 | |
| XVR 20-2 | RE011979 | RE011999 | | 1/2"x5/16" | 20 | 55 | 55 | | 14 | 20.5 | | 10 | 35 | 7 | M10 | 0.10 | 0.11 | | |
| XVR 30-2 | RE011979 | RE012000 | RE012017 | 1/2"x5/16" | 30 | 55 | 60 | 70 | 14 | 20.5 | 34 | 10 | 35 | 7 | M10 | 0.11 | 0.12 | 0.13 | |
| XVR 30-3 | RE011981 | RE012001 | | 5/8"x3/8" | 30 | 55 | 70 | | 16.5 | 25 | | 12 | 45 | 9 | M10 | 0.12 | 0.14 | | |
| XVR 40-3 | | | RE012019 | 5/8"x3/8" | 40 | | | 100 | | | 42 | 12 | 45 | 9 | M12 | | | 0.27 | |
| XVR 30-4 | RE011983 | RE012003 | | 3/4"x7/16" | 30 | 60 | 70 | | 17.5 | 30 | | 12 | 45 | 11 | M10 | 0.13 | 0.15 | | |
| XVR 40-4 | RE011984 | RE012004 | RE012021 | 3/4"x7/16" | 40 | 80 | 80 | 100 | 17.5 | 30 | 49 | 12 | 45 | 11 | M12 | 0.20 | 0.22 | 0.28 | |
| XVR 40-5 | RE011986 | RE012006 | RE012023 | 1"x17.02mm | 40 | 80 | 90 | 100 | 18 | 47 | 79.5 | 20 | 55 | 16 | M12 | 0.22 | 0.31 | 0.44 | |

S: 具单滑块配件 / kit with simplex sliding block

D: 具双滑块配件 / kit with duplex sliding block

T: 具三滑块配件 / kit with triplex sliding block

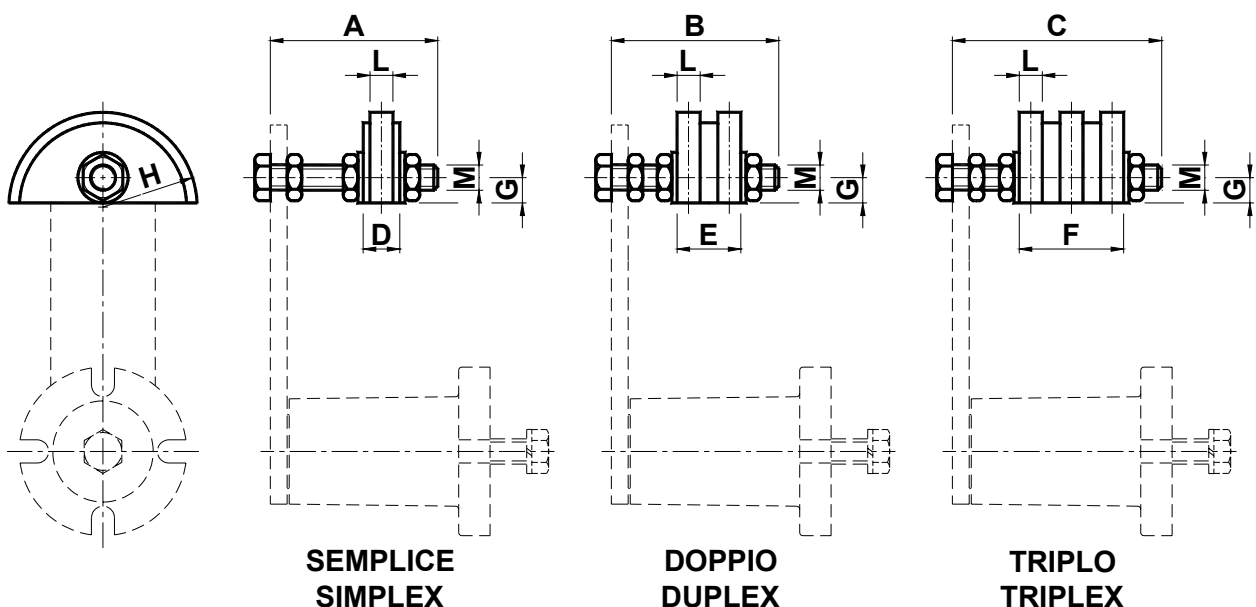

附件 型号 XOV / XOV accessories



具高分子密度的聚乙烯椭圆形 XOV 滑块，适用于以经济的方式对速度不超过0.35m/s的单排和双排链条进行张紧，工作温度低于 80°C。

这个型号的滑块尤其适用于靠近链轮的安装和中低轴距。与传统 XVR 型滑块相比，其特殊的形状允许双面使用，保证加倍的使用寿命。所供应配件包括所有的不锈钢螺钉螺栓。

UK XOV elliptical sliding block in polyethylene with an high molecular density, suitable to tension in a cheaper way simplex, duplex or triplex chains which have a speed not higher than 0,35m/s and operating temperatures lower than 80°C.

This type of sliding block is particularly suitable for installations close to the pinion and for reduced interaxis and the particular shape allows to used it on both the sides, granting an useful life which is double with respect to the one of the traditional XVR type sliding block. The kits are delivered complete with stainless steel bolts and screws.

| 型号 Type | S 编号 n° | D 编号 n° | T 编号 n° | 链条 Chain | Size  | A | B | C | D | L | M | N | O | 重量 Weight [Kg] | | |
|------------|------------|------------|------------|-------------|--|----|----|-----|------|----|-----|----|-----|----------------|------|------|
| | | | | | | | | | | | | | | S | D | T |
| XOV 10-1 | RE013001 | RE013021 | | 3/8"x7/32" | 10 | 45 | 45 | | 10.2 | 5 | M 8 | 40 | 75 | 0.09 | 0.10 | |
| XOV 20-1 | | | RE013040 | 3/8"x7/32" | 20 | | | 55 | 10.2 | 7 | M10 | 40 | 75 | | | 0.11 |
| XOV 20-2 | RE013004 | RE013024 | | 1/2"x5/16" | 20 | 55 | 55 | | 13.9 | 7 | M10 | 50 | 96 | 0.10 | 0.11 | |
| XOV 30-2 | RE013004 | RE013025 | RE013042 | 1/2"x5/16" | 30 | 55 | 60 | 75 | 13.9 | 9 | M10 | 50 | 96 | 0.11 | 0.12 | 0.13 |
| XOV 30-3 | RE013006 | RE013026 | | 5/8"x3/8" | 30 | 55 | 70 | | 16.6 | 11 | M10 | 65 | 126 | 0.12 | 0.14 | |
| XOV 40-3 | | | RE013044 | 5/8"x3/8" | 40 | | | 90 | 16.6 | 11 | M12 | 65 | 126 | | | 0.16 |
| XOV 30-4 | RE013008 | RE013028 | | 3/4"x7/16" | 30 | 60 | 70 | | 19.5 | 5 | M10 | 74 | 148 | 0.13 | 0.15 | |
| XOV 40-4 | RE013009 | RE013029 | RE013046 | 3/4"x7/16" | 40 | 80 | 80 | 100 | 19.5 | 7 | M12 | 74 | 148 | 0.20 | 0.22 | 0.25 |

S: 具单滑块配件 / kit with simplex sliding block

D: 具双滑块配件 / kit with duplex sliding block

T: 具三滑块配件 / kit with triplex sliding block

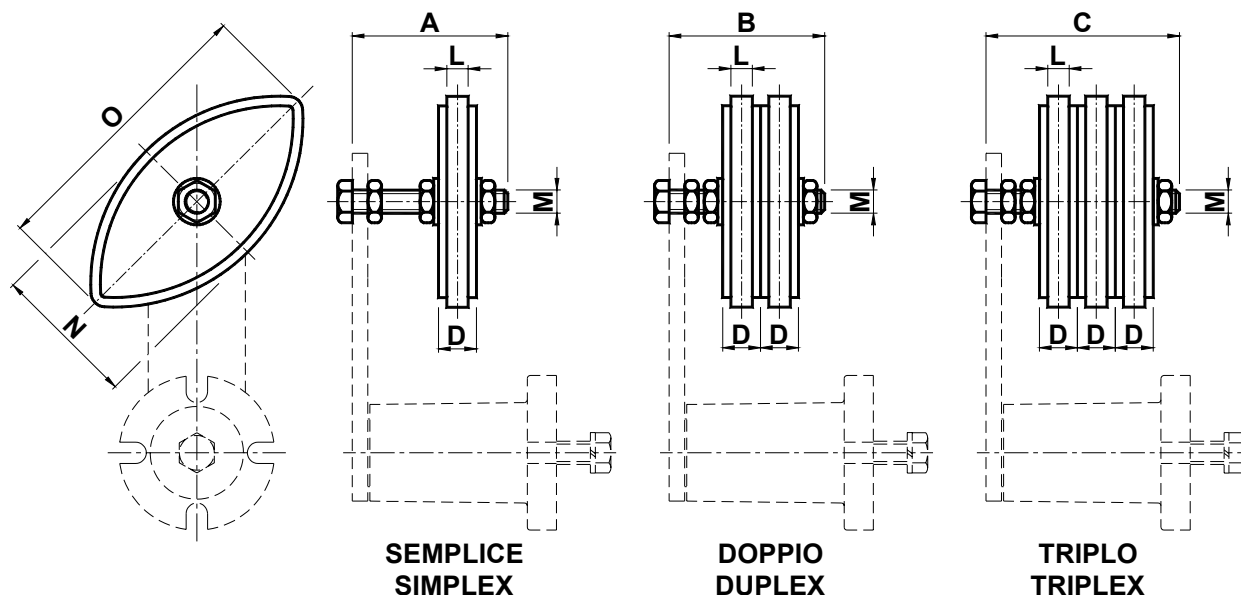

附件 型号 XRO / XRO accessories



具高分子密度的聚乙烯 XRO 滑轮，在钢制衬套上转动，适用于以经济的方式对速度不超过0,55m/s的单排、双排和三排链条进行张紧，工作温度低于 80°C。

这个型号的滑块尤其适用于靠近链轮的安装和低轴距，或者有高缠绕角度必要时的安装。所供应配件包括所有的不锈钢螺钉螺栓。

UK XRO polyethylene wheel with an high molecular density that turns on a steel bush, suitable to tension in a cheaper way simplex, duplex or triplex chains which have a speed not higher than 0,55m/s and operating temperatures lower than 80°C.

This type of sliding block is particularly suitable for installations close to the pinion and for reduced interaxis, or in the cases it is necessary an high winding angle. The kits are delivered complete with stainless steel bolts and screws.

| 型号 Type | S 编号 n° | D 编号 n° | T 编号 n° | 链条 Chain | Size  | A | B | C | D | E | F | ØH | L | M | 重量 Weight [Kg] | | |
|------------|------------|------------|------------|-------------|--|----|----|-----|----|----|----|-----|-----|-----|-------------------|------|------|
| | | | | | | S | D | T | | | | | | | | | |
| XRO 10-0 | RE012095 | RE012115 | | 8mm | 10 | 45 | 45 | | 18 | 18 | | 70 | 2.5 | M 8 | 0.14 | 0.15 | |
| XRO 10-1 | RE012096 | RE012116 | | 3/8"x7/32" | 10 | 45 | 50 | | 18 | 18 | | 70 | 5 | M 8 | 0.14 | 0.15 | |
| XRO 20-1 | | | RE012135 | 3/8"x7/32" | 20 | | | 60 | | | 36 | 70 | 5 | M10 | | | 0.21 |
| XRO 20-2 | RE012099 | RE012119 | | 1/2"x5/16" | 20 | 55 | 55 | | 18 | 36 | | 70 | 7 | M10 | 0.15 | 0.20 | |
| XRO 30-2 | RE012099 | RE012120 | RE012137 | 1/2"x5/16" | 30 | 55 | 60 | 70 | 18 | 36 | 36 | 70 | 7 | M10 | 0.16 | 0.22 | 0.23 |
| XRO 30-3 | RE012101 | RE012121 | | 5/8"x3/8" | 30 | 55 | 70 | | 18 | 36 | | 90 | 9 | M10 | 0.19 | 0.29 | |
| XRO 40-3 | | | RE012139 | 5/8"x3/8" | 40 | | | 100 | | | 49 | 90 | 9 | M12 | | | 0.43 |
| XRO 30-4 | RE012103 | RE012123 | | 3/4"x7/16" | 30 | 55 | 70 | | 18 | 36 | | 90 | 11 | M10 | 0.19 | 0.29 | |
| XRO 40-4 | RE012104 | RE012124 | RE012141 | 3/4"x7/16" | 40 | 80 | 80 | 100 | 18 | 36 | 49 | 90 | 11 | M12 | 0.25 | 0.35 | 0.46 |
| XRO 40-5 | RE012106 | RE012126 | RE012143 | 1"x17.02mm | 40 | 80 | 90 | 100 | 18 | 49 | 82 | 110 | 16 | M12 | 0.32 | 0.56 | 0.70 |

S: 具单滑轮配件 / kit with simplex wheel

D: 具双滑轮配件 / kit with duplex wheel

T: 具三滑轮配件 / kit with triplex wheel

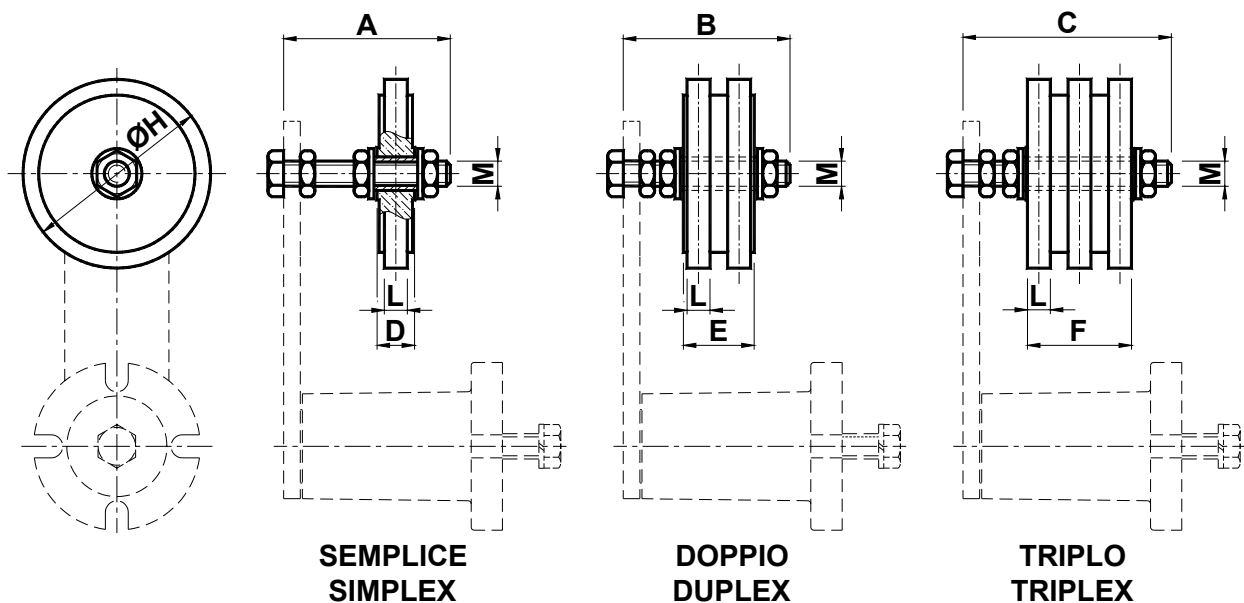

附件 型号 XZN-AZN / XZN - AZN accessories



链条拉紧装置用塑料链轮 XZN 和 AZN，具底部扩大的国产轴承，适用于对速度不超过 1m/s 的单排链条进行张紧，工作温度低于 100°C。所供应配件包括不锈钢(XZN)或镀锌(AZN)螺钉螺栓。

UK XZN and AZN plastic pinion tighteners with national enlarged bearing, suitable to tension simplex chains which have a speed not higher than 1m/s and operating temperatures lower than 100°C. The kits are delivered complete with stainless steel bolts and screws (XZN) or galvanized bolts and screws (AZN).

| 型号 Type | 编号 n° | 链条 Chain | Size  | A | ØH | L | ØP | M | Z | 重量 Weight [Kg] | 编号 n° | 型号 Type |
|------------|----------|-------------|---|----|------|-----|-------|-----|----|-------------------|----------|------------|
| XZN 20-1S | RE012155 | 3/8"x7/32" | 20 | 55 | 68.0 | 5.3 | 63.90 | M10 | 21 | 0.28 | RE012440 | AZN 20-1S |
| XZN 30-1S | RE012156 | 3/8"x7/32" | 30 | 55 | 68.0 | 5.3 | 63.90 | M10 | 21 | 0.28 | RE012441 | AZN 30-1S |
| XZN 30-2S | RE012158 | 1/2"x5/16" | 30 | 55 | 77.8 | 7.2 | 73.14 | M10 | 18 | 0.30 | RE012443 | AZN 30-2S |
| XZN 30-3S | RE012159 | 5/8"x3/8" | 30 | 60 | 93.0 | 9.1 | 86.39 | M10 | 17 | 0.33 | RE012444 | AZN 30-3S |
| XZN 40-3S | RE012160 | 5/8"x3/8" | 40 | 80 | 93.0 | 9.1 | 86.39 | M12 | 17 | 0.35 | RE012445 | AZN 40-3S |

PI : 塑料链轮和不锈钢螺钉 / plastic pinion and stainless steel screw

PZ: 塑料链轮和镀锌螺钉 / plastic pinion and galvanized steel screw

Z : 齿数 / number of teeth

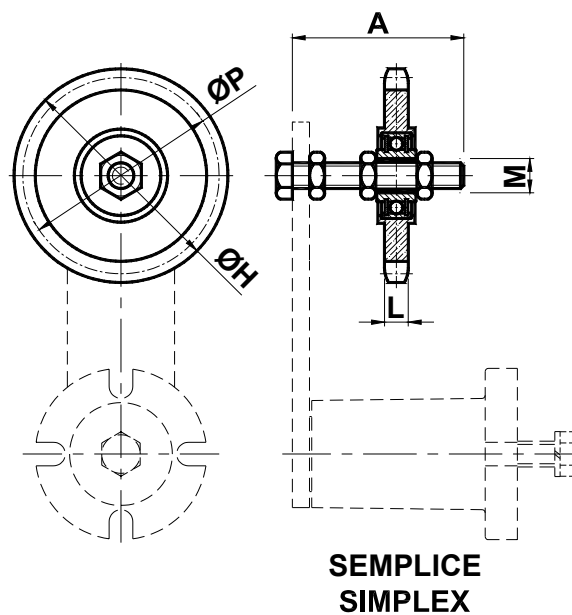

附件 型号 XZK / XZK accessories



链条拉紧装置用不锈钢链轮 XZK，具轴承，适用于对速度不超过 1m/s 的双排和三排链条进行张紧，工作温度低于 100°C。所供应配件包括不锈钢螺钉螺栓。

UK XZK stainless steel pinion tightener with bearing, suitable to tension simplex, duplex and triplex chains which have a speed not higher than 1m/s and operating temperatures lower than 100°C. The kits are delivered complete with Inox bolts and screws.

| 型号 Type | S 编号 n° | D 编号 n° | T 编号 n° | 链条 Chain | Size  | | | | | | | | | 重量 Weight [Kg] | | | |
|------------|------------|------------|------------|-------------|---|-----|-----|----|----|-------|------|--------|-----|-------------------|------|------|------|
| | | | | | | A | B | C | D | ØH | L | ØP | M | Z | S | D | T |
| XZK 20-1 | RE012310 | RE012340 | | 3/8"x7/32" | 20 | 55 | 55 | | 9 | 49.3 | 5.3 | 45.81 | M10 | 15 | 0.13 | 0.23 | |
| XZK 30-1 | RE012310 | RE012341 | RE012370 | 3/8"x7/32" | 30 | 55 | 60 | 70 | 9 | 49.3 | 5.3 | 45.81 | M10 | 15 | 0.13 | 0.23 | 0.26 |
| XZK 30-2 | RE012314 | RE012344 | | 1/2"x5/16" | 30 | 55 | 60 | | 9 | 65.5 | 7.2 | 61.09 | M10 | 15 | 0.21 | 0.37 | |
| XZK 40-2 | | | RE012374 | 1/2"x5/16" | 40 | | | 80 | 12 | 65.5 | 7.2 | 61.09 | M12 | 15 | | | 0.51 |
| XZK 40-3 | RE012318 | RE012348 | RE012377 | 5/8"x3/8" | 40 | 80 | 80 | 80 | 12 | 83.0 | 9.1 | 76.36 | M12 | 15 | 0.38 | 0.60 | 0.96 |
| XZK 40-4 | RE012321 | RE012351 | RE012381 | 3/4"x7/16" | 40 | 80 | 80 | 90 | 12 | 99.8 | 11.1 | 91.63 | M12 | 15 | 0.56 | 1.00 | 1.50 |
| XZK 40-5 | RE012325 | RE012355 | | 1"x17.02mm | 40 | 100 | 120 | | 12 | 117.0 | 16.2 | 106.12 | M12 | 13 | 1.00 | 1.90 | |

Z: 齿数 / number of teeth

S: 具单链轮的配套元件 / kit with a simplex pinion

D: 具双链轮的配套元件 / kit with a duplex pinion

T: 具三链轮的配套元件 / kit with a triplex pinion

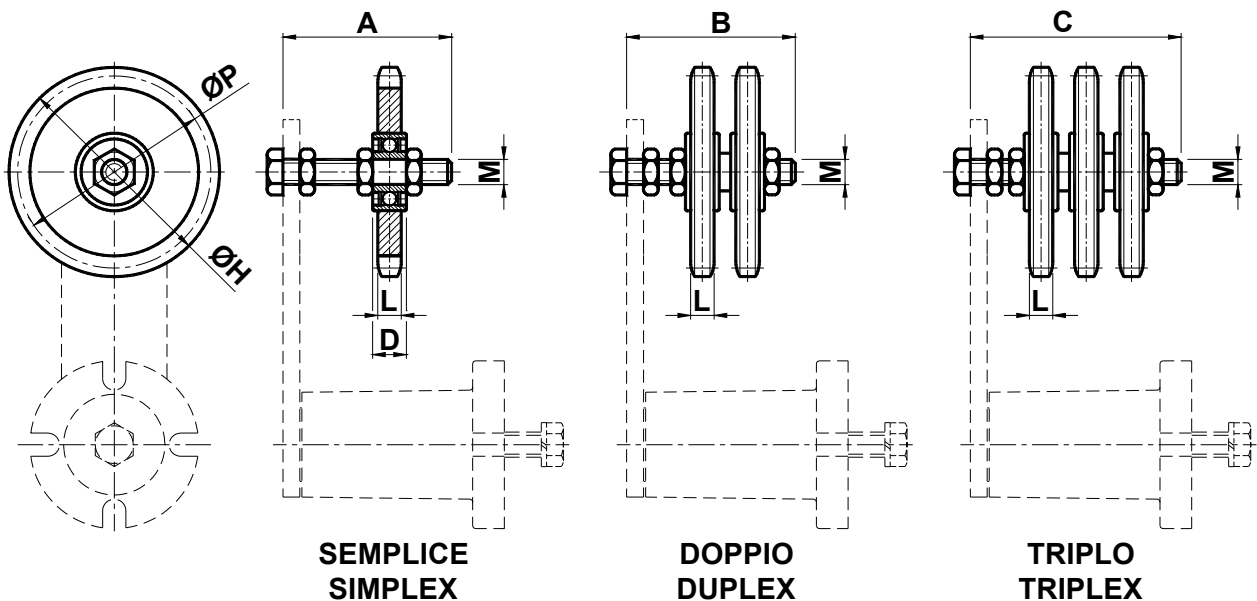

附件 型号 XRP / XRP accessories

 XRP 塑性材质滚轮在自润滑轴承上安装，适用于皮带的张紧。工作温度应为 $\leq 70^{\circ}\text{C}$ 。所供应配件包括不锈钢螺钉螺栓。

 XRP plastic roller installed on self-lubricating bearings, suitable to tension the belts. The operating temperatures must be $\leq 70^{\circ}\text{C}$. The kits are delivered with stainless steel bolts and screws.

| 型号 Type | 编号 n° | Size  | Size | | | | | M | 重量 Weight [Kg] |
|------------|----------|---|------|---|----|----|----|-----|-------------------|
| | | | A | B | C | D | E | | |
| XRP 1 | RE011960 | 10 | 35 | 3 | 13 | 40 | 30 | M 8 | 0.08 |
| XRP 2/3 | RE011962 | 20-30 | 45 | 6 | 16 | 53 | 40 | M10 | 0.18 |
| XRP 4 | RE011964 | 40 | 60 | 8 | 21 | 70 | 60 | M12 | 0.40 |

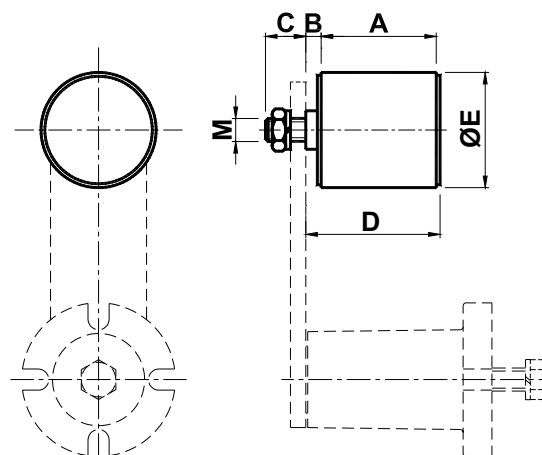

附件 型号 XRU / XRU accessories

 XRU 不锈钢滚轮在自润滑轴承上安装，适用于皮带的张紧。工作温度应为 $\leq 70^{\circ}\text{C}$ 。所供应配件包括不锈钢螺钉螺栓。

 XRU stainless steel roller installed on self-lubricating bearings, suitable to tension the belts. The operating temperatures must be $\leq 100^{\circ}\text{C}$. The kits are delivered with stainless steel bolts and screws.

| 型号 Type | 编号 n° | Size  | Size | | | | | M | 重量 Weight [Kg] |
|------------|----------|---|------|---|----|----|----|-----|-------------------|
| | | | A | B | C | D | E | | |
| XRU 1 | RE010970 | 10 | 35 | 3 | 13 | 40 | 30 | M 8 | 0.16 |
| XRU 2/3 | RE010972 | 20-30 | 45 | 6 | 16 | 53 | 40 | M10 | 0.37 |
| XRU 4 | RE010974 | 40 | 60 | 8 | 21 | 72 | 60 | M16 | 0.85 |

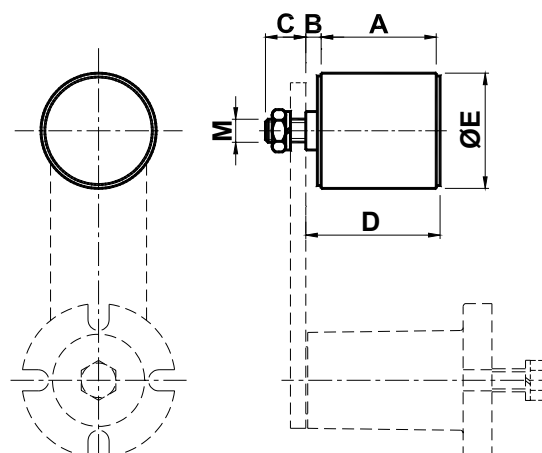

SN 塑料弹性组件 / SN Elastic elements in plastic



SN 弹性组件用塑性材料制造，其中包括镀锌钢螺钉螺栓；若有需求，可提供不锈钢螺钉螺栓。
这项产品适用与小型张紧装置和小型压力组。

The SN elastic element is made of plastic material and it is delivered with galvanized steel bolts and screws; on demand, we can made it also with stainless steel bolts and screws.
This product is suitable to make mini tensioners and small pressure units.

| 型号 Type | 编号 n° | Newton | A | B | C | D | E | F | G | H | L | M | N | O | P | Q | R | 重量 Weight [Kg] |
|------------|----------|--------|------|------|------|----|---|----|------|------|----|------|----|-----|------|------|-------|----------------------|
| SN 5 | RE010880 | 0 - 18 | 34.5 | 60.0 | 68.7 | 27 | 6 | 32 | 13.5 | 2.75 | 15 | 25.5 | 29 | 3.3 | 6.7 | 11.4 | M4x40 | 0.05 |
| SN 10 | RE010890 | 0 - 90 | 47.1 | 80.1 | 92.5 | 51 | 8 | 58 | 28.6 | 4.6 | 25 | 35.0 | 40 | 4.4 | 10.2 | 14.7 | M6x70 | 0.12 |

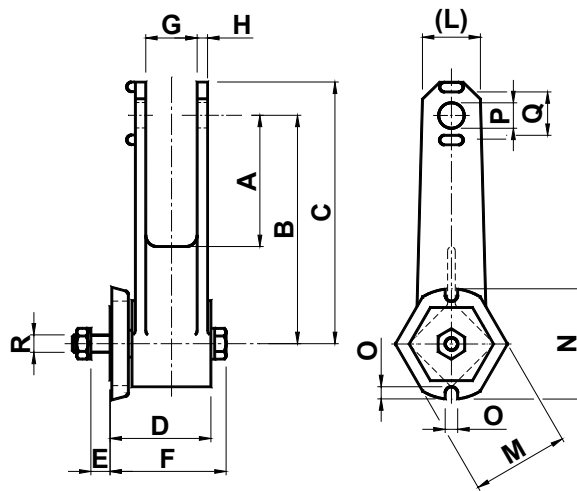

一般销售条件：

- 1) **订货** – 标准材料或特殊材料的订货应始终根据TECNIDEA CIDUE S.r.l. 公司的报价作出。所有的订货对客户都是有约束力的。加工生产一旦开始，便不可接受取消订货或减少订货，除非客户一方赔偿直至中止时刻所使用的材料和加工费用。无论如何，这些费用将由 TECNIDEA CIDUE S.r.l.公司决定。
- 2) **价格** – 意指在订货日期有效的价格。所有的价格均为维罗纳交货价计价，包装费除外。如果在供应工程中出现材料费或其他生产费用的增长情况，TECNIDEA CIDUE S.r.l.公司有权根据相应的增长修正价格，这一点也包括已在进行过程中的订货。
- 3) **交货期限** – 唯有TECNIDEA CIDUE S.r.l.公司所指定的交货期限为有效期限。无论如何，此期限只是具有说明意义的。若存在材料供应困难和罢工的情况，或者在任何不可抗力力的情况下，交货期限将自动延期，TECNIDEA CIDUE S.r.l.公司没有义务赔偿任何可能的相关损失。材料准备完毕，客户在任何情况下有义务提取所订的材料。
- 4) **运输** – 运输费由订货方负担，即使是到岸计价，风险和危险也由其承担。就可能发生的短装货投诉应在接收货物后8天内提出。如果经商议，运输费由TECNIDEA CIDUE S.r.l.公司负担，或者仅是部分负担，公司保留可选择最经济的运输方式的权利。
- 5) **包装** – 包装费在费用价格中计算。
- 6) **退货** – 如果未经事先批准或有包装费，不接受具任何理由的退货，可能存在的海关手续费及退货完全由买方负担。仓库存放或管理费用用保证金的将以退货价值的15%计算并通过欠款通知账单的方式而发放。
- 7) **质量保证** – TECNIDEA CIDUE S.r.l.公司将致力于免费修理或更换由其认定有缺陷的部件。有争议的货物应交还 TECNIDEA CIDUE S.r.l.公司所在地，所有费用均免。在将有缺陷的部件修理或拆开复原后，保质期到期。由买方对有缺陷的部件进行的修理仅在 TECNIDEA CIDUE S.r.l. 公司批准并同意费用预定价的情况下得到承认。
TECNIDEA CIDUE S.r.l.公司对在用户使用其产品，包括有缺陷产品的过程中所造成的损害不负任何责任，也不偿付任何相关的赔款。
- 8) **责任** - TECNIDEA CIDUE S.r.l.公司对在用户使用其产品，包括由缺陷产品的过程中所造成的损害不负任何责任，也不偿付任何相关的赔款。TECNIDEA CIDUE S.r.l.公司按照从属客户提出的特殊细节制造产品，但是对此产品是否由专利保护不负任何责任。
- 9) **付款** – 只有在所商议的方式和期限内所做的付款被认为有效。在付款期过后，TECNIDEA CIDUE S.r.l.公司有权要求付款，并将以超过法定税率以上3%的税率计算罚款利息。在订货方延迟付款或不付款的情况下，TECNIDEA CIDUE S.r.l.公司有权中断在进行过程中的订货的送交或者提出提前付款的要求，无需向订货方保证任何的赔款或赔偿。在生产过程中或材料已由订货方拥有，对材料提出的任何争议不解除订货方在确定期限内付款的义务，应付全部款项并不可要求任何的折扣。
- 10) **财产** – 在就发票额完全支付款项之前，一切寄出的货物仍为TECNIDEA CIDUE S.r.l.公司的财产。
- 11) **主管法院** – 与TECNIDEA CIDUE S.r.l.商业关系相联的任何争议将为维罗纳法院的权限。

N.B. Fa fede la versione in Italiano o Inglese.

注：所有的文件以意大利文或英文版为准。



Tecnidea Cidue srl 敬告这些数据不是绝对严格，公司有权不经过事先通知，根据为改善产品质量的适当的需求而进行变更。

Customers are advised that the data given here may change. Tecnidea Cidue srl reserves the right to alter the nature of its product to suit new requirements and improve quality without forewarning clients.



TECNIDEA CIDUE S.r.l.
Via Apollo XI, 12 (trav. Via Cavrara)
37057 S. Giovanni Lupatoto - Verona - Italy
tel. 0039 (0)45 8750250 - fax 0039 (0)45 8750288
www.tecnideacidue.com
e-mail: sales@tecnideacidue.com

as ideas ideas ideas ideas

Tecnidea Cidue Worldwide

Austria - Belgium - Bulgaria - Czech republic - Denmark
Finland - France - Germany - Greece - Hungary
Ireland - Italy - Latvia - Lithuania - Malta - Netherlands
Norway - Poland - Portugal - Romania - Slovakia
Slovenia - Spain - Sweden - Switzerland - Ukraine
United Kingdom - Argentina - Australia - Brasil
Canada - China - Chile - India - Indonesia - Iran - Israel
Japan - Jordan - South Korea - Mexico - New Zeeland
Peru - Philippines - Russia - Singapore - Taiwan
Thailand - Tunisia - Turkey - U.S.A.

