

张紧装置附件 型号 T

Accessories for chain Tighteners type T

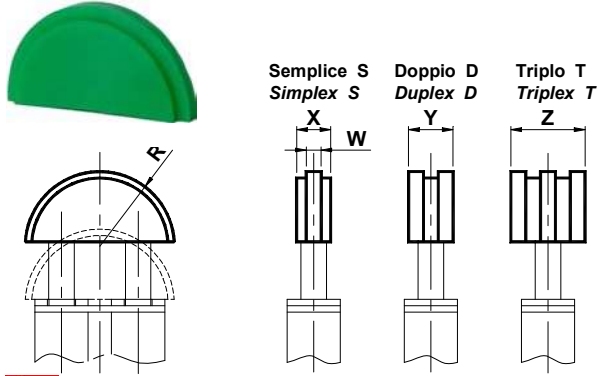

具半圆形轮廓滑块，适用于小轴距和靠近链轮的安装。

材料：高分子密度聚乙烯。

工作速度 ≤20 m/min。工作温度 ≤70°C。

Semi-circular sliding block suitable for reduced interaxis or for installation closed to the pinion.

Material: Polyethylene high molecular density.

Operating speed ≤20 m/min. Sliding block operating temperature ≤70°C.



张紧装置附件 型号 R

Accessories for chain Tighteners type R

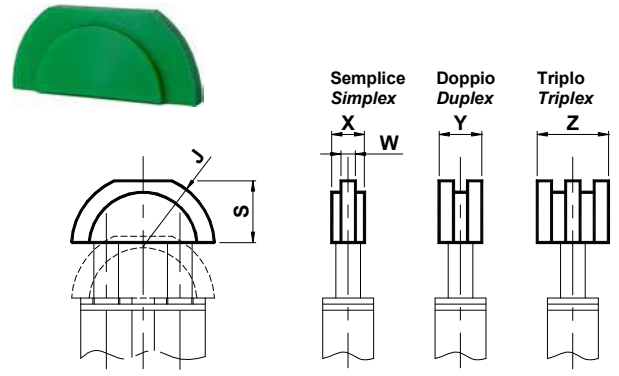

具半圆形轮廓滑块，适用于大轴距。

材料：高分子密度聚乙烯。

工作速度 ≤20 m/min。工作温度 ≤70°C。

Semi-circular lowered sliding block suitable for large interaxis.

Material: Polyethylene with high molecular density.

Operating speed ≤20 m/min. Sliding block operating temperature ≤70°C.



型号 Type	编号 S	编号 D	编号 T	J	R	S	W	X	Y	Z	重量 Weight [Kg]			型号 Type	编号 S	编号 D	编号 T
											S	D	T				
T1 3/8"	AS01006	AS01007	AS01009	35	35	30	5	1	18	25	0.03	0.03	0.04	R1 3/8"	AS010396	AS010411	AS010426
T1 1/2"	AS01006	AS01007	AS01009	35	35	30	7	1	20.5	34	0.03	0.03	0.06	R1 1/2"	AS010397	AS010412	AS010427
T1 5/8"	AS01006	AS01007	AS01009	45	35	37	9	1	25	42	0.03	0.03	0.06	R1 5/8"	AS010398	AS010413	AS010428
T2 5/8"	AS01006	AS01007	AS01009	45	45	37	9	1	25	42	0.04	0.08	0.12	R2 5/8"	AS010399	AS010414	AS010429
T2 3/4"	AS01006	AS01008	AS01009	45	45	37	1	1	30	49	0.05	0.09	0.14	R2 3/4"	AS010400	AS010415	AS010430
T3 1"	AS01006	AS01008	AS01009	55	55	46	1	1	47	79	0.08	0.20	0.32	R3 1"	AS010401	AS010416	AS010431
T3 1" 1/4	AS01006	AS01008	AS01009	55	55	46	1	2	54	91	0.32	0.50	0.60	R3 1" 1/4	AS010402	AS010417	AS010432
T3 1" 1/2	AS010068	AS010083	AS010098	55	55	46	24	24	72	120	0.33	0.54	0.65	R3 1" 1/2	AS010403	AS010418	AS010433

张紧装置附件 型号 S / Accessories for chain tighteners type S

适用于大轴距的滑块。材料：高分子密度聚乙烯。

工作速度 ≤20 m/min。工作温度 ≤70°C。

Sliding block for large interaxis. Material: Polyethylene with high molecular density.

Operating speed ≤20 m/min. Sliding block operating temperature ≤70°C.

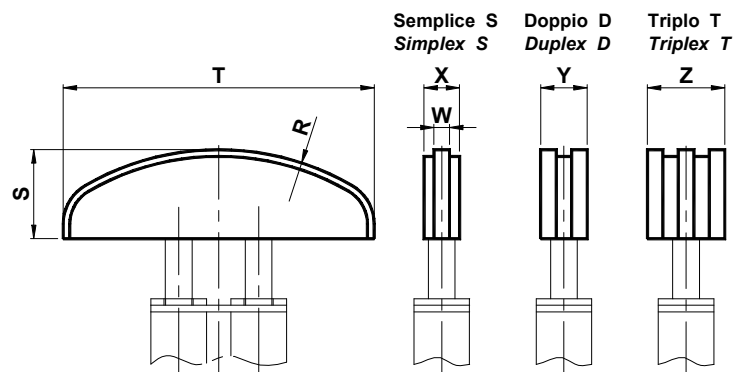

型号 Type	编号 S	编号 D	编号 T	R	S	T	W	X	Y	Z	重量 Weight [Kg]		
											S	D	T
S1 3/8"	AS010115	AS010130	AS010145	120	40	140	5	20	20	25	0.08	0.08	0.10
S1 1/2"	AS010116	AS010131	AS010146	120	40	140	7	20	20	35	0.08	0.08	0.12
S2 5/8"	AS010117	AS010132	AS010147	140	40	140	9	20	25	42	0.10	0.12	0.30
S2 3/4"	AS010118	AS010133	AS010148	140	40	140	11	20	30	49	0.12	0.65	0.35
S3 1"	AS010119	AS010134	AS010149	160	40	140	16	25	45	79.5	0.20	0.50	0.80
S3 1" 1/4	AS010120	AS010135	AS010150	160	40	140	18	25	54	90	0.80	1.30	1.50
S3 1" 1/2	AS010121	AS010136	AS010151	160	40	140	24	25	72	120	0.80	1.30	1.60