

Accessoires pour tendeurs de chaîne type T Accessories for chain Tighteners type T

Accessoires pour tendeurs de chaîne type R Accessories for chain Tighteners type R

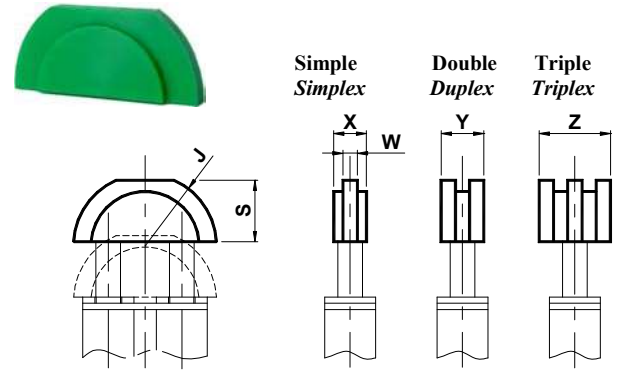
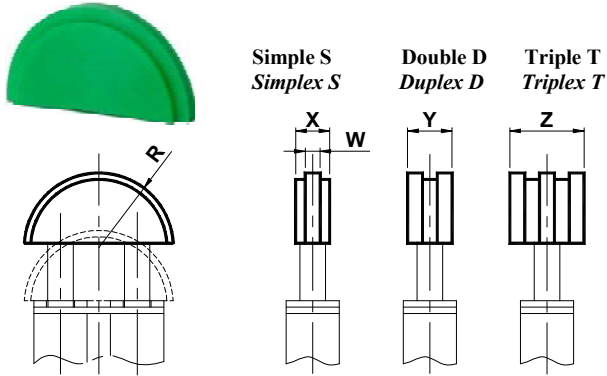

Patin à profil semi-circulaire, adapté pour les petits entraxes et le montage près d'un pignon.
Matériau: Polyéthylène à haute densité moléculaire.
Vitesse de travail ≤ 20 m/min. Température de fonctionnement $\leq 70^{\circ}\text{C}$.

Patin à profil semi-circulaire abaissé, adapté pour les grands entraxes.
Matériau: Polyéthylène à haute densité moléculaire.
Vitesse de travail ≤ 20 m/min. Température de fonctionnement $\leq 70^{\circ}\text{C}$.

Semi-circular sliding block suitable for reduced interaxis or for installation closed to the pinion.
Material: Polyethylene high molecular density.
Operating speed ≤ 20 m/min. Sliding block operating temperature $\leq 70^{\circ}\text{C}$.

Semi-circular lowered sliding block suitable for large interaxis.
Material: Polyethylene with high molecular density.
Operating speed ≤ 20 m/min. Sliding block operating temperature $\leq 70^{\circ}\text{C}$.

Type Type	code S	code D	code T	J	R	S	W	X	Y	Z	Poids Weight [Kg]			Type Type	code S	code D	code T
											S	D	T				
T1 3/8"	AS010061	AS010076	AS010091	35	35	30	5	16	18	25	0.03	0.03	0.04	R1 3/8"	AS010396	AS010411	AS010426
T1 1/2"	AS010062	AS010077	AS010092	35	35	30	7	16	20.5	34	0.03	0.03	0.06	R1 1/2"	AS010397	AS010412	AS010427
T1 5/8"	AS010063	AS010078	AS010093	45	35	37	9	17	25	42	0.03	0.03	0.06	R1 5/8"	AS010398	AS010413	AS010428
T2 5/8"	AS010064	AS010079	AS010094	45	45	37	9	17	25	42	0.04	0.08	0.12	R2 5/8"	AS010399	AS010414	AS010429
T2 3/4"	AS010065	AS010080	AS010095	45	45	37	11	17	30	49	0.05	0.09	0.14	R2 3/4"	AS010400	AS010415	AS010430
T3 1"	AS010066	AS010081	AS010096	55	55	46	16	18	47	79.5	0.08	0.20	0.32	R3 1"	AS010401	AS010416	AS010431
T3 1" 1/4	AS010067	AS010082	AS010097	55	55	46	18	20	54	91	0.32	0.50	0.60	R3 1" 1/4	AS010402	AS010417	AS010432
T3 1" 1/2	AS010068	AS010083	AS010098	55	55	46	24	24	72	120	0.33	0.54	0.65	R3 1" 1/2	AS010403	AS010418	AS010433

Accessoires pour tendeurs de chaîne type S / Accessories for chain tighteners type S

Patin pour grands entraxes. Matériau: polyéthylène à haute densité moléculaire.
Vitesse de travail ≤ 20 m/min. Température de fonctionnement $\leq 70^{\circ}\text{C}$.

Sliding block for large interaxis. Material: Polyethylene with high molecular density.
Operating speed ≤ 20 m/min.

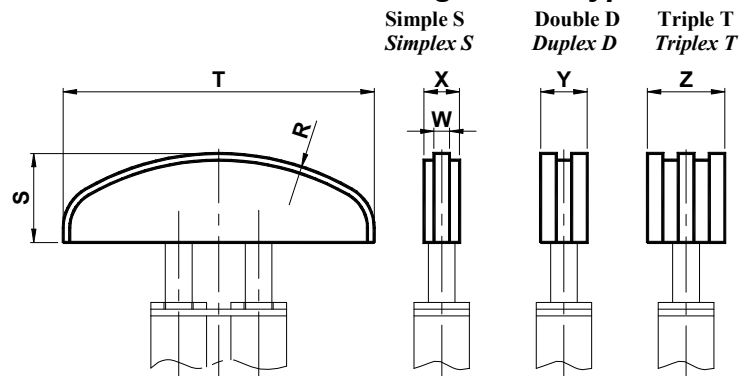

Type Type	code S	code D	code T	R	S	T	W	X	Y	Z	Poids Weight [Kg]		
											S	D	T
S1 3/8"	AS010115	AS010130	AS010145	120	40	140	5	20	20	25	0.08	0.08	0.10
S1 1/2"	AS010116	AS010131	AS010146	120	40	140	7	20	20	35	0.08	0.08	0.12
S2 5/8"	AS010117	AS010132	AS010147	140	40	140	9	20	25	42	0.10	0.12	0.30
S2 3/4"	AS010118	AS010133	AS010148	140	40	140	11	20	30	49	0.12	0.65	0.35
S3 1"	AS010119	AS010134	AS010149	160	40	140	16	25	45	79.5	0.20	0.50	0.80
S3 1" 1/4	AS010120	AS010135	AS010150	160	40	140	18	25	54	90	0.80	1.30	1.50
S3 1" 1/2	AS010121	AS010136	AS010151	160	40	140	24	25	72	120	0.80	1.30	1.60