

TEN BLOC“抗扭转”“单向”弹簧式弹性组件 – 型号: TBAB

TEN BLOC Elastic spring Elements “anti-rotation” “one-directional” – Type: TBAB

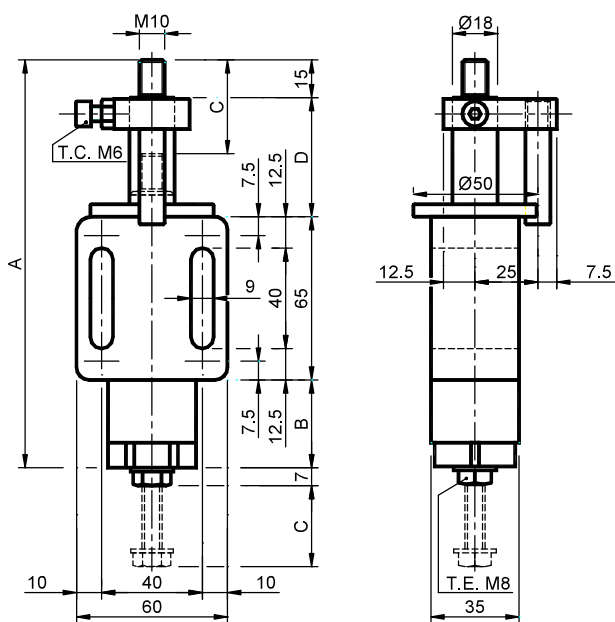

材料 铝制主体配黄铜轴承。套环为黄铜制。圆柱、堵盖、圆筒、小金属板、螺钉、桩销和弹簧均为钢制。

处理 喷砂铝，局部为镀锌钢，粗加工弹簧涂油。

应用 “抗扭转”“单向”弹簧式弹性组件。链条或皮带的游隙通过弹簧的运动自动补偿。“抗扭转”命名意指圆柱在安装之后，不可自由地在 360°角度扭转。“单向”命名意指圆柱只能作推出动作，不能自由地重新进入。

C: 张紧装置行程。



MATERIALS Body made of aluminium with brushing made of brass. Collar made of brass. Column, cap, cylinders, plate, stake, screw and spring made of steel.

TREATMENTS Sandblasted aluminium, components made of galvanized steel, greased raw spring.

USE Elastic spring Element “anti-rotation” and “one-directional”. The recover of chain- or belt- slack takes place automatically through the spring action. The word “anti-rotation” means that the column, when it is positioned, isn’t no more free to rotate to 360°. The word “one-directional” means that the column has a movement only in thrust and it isn’t free to reenter.

C: Tightener travel.

型号 Type	编号 N°	A	B	C	D	Newton	重量 Weight in Kg
TBAB 10	TB013120	145	35	27	30	30 ÷ 100	0.80
TBAB 20	TB013121	145	35	27	30	60 ÷ 170	0.80
TBAB 30	TB013122	145	35	26	30	90 ÷ 250	0.80
TBAB 40	TB013123	155	45	30	30	100 ÷ 400	0.84
TBAB 50	TB013124	170	60	30	30	180 ÷ 700	0.93
TBAB 60	TB013125	205	95	30	30	220 ÷ 1000	1.10
TBAB 70	TB013126	225	115	30	30	340 ÷ 1500	1.22
TBAB 80	TB013127	225	115	30	30	400 ÷ 2000	1.24
TBAB 90	TB013128	270	160	30	30	500 ÷ 2500	1.60

