

皮带张紧装置配套元件 / KIT for belt-tighteners

聚酰胺滚轮 – 型号: **FP** / 镀锌钢滚轮 – 型号: **FU**

*Rollerset in polyamid – Type: **FP** /*

*Rollerset in galvanized steel – Type **FU***



FP



FU

配套元件由一个镀锌钢制支架和空转滚轮组成。滚轮可为聚酰胺 (FP), 或镀锌钢(FU), 在润滑轴承上安装。滚轮工作温度 $\leq 80^{\circ}\text{C}$ 。客户应指定安装定位 (H 或 Y), 否则将以操作方式 H 提供。

The kit is made up by a painted steel fork with idle rollerset. The rollerset can be in polyamid (FP) or in galvanized steel (FU), installed on greased bearings. Operating temperature of the rollerset $\leq 80^{\circ}\text{C}$. Please specify the positioning (H or Y), otherwise it will be supplied with H execution.

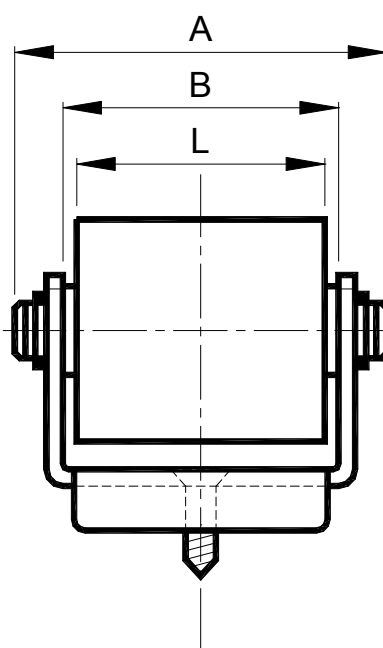
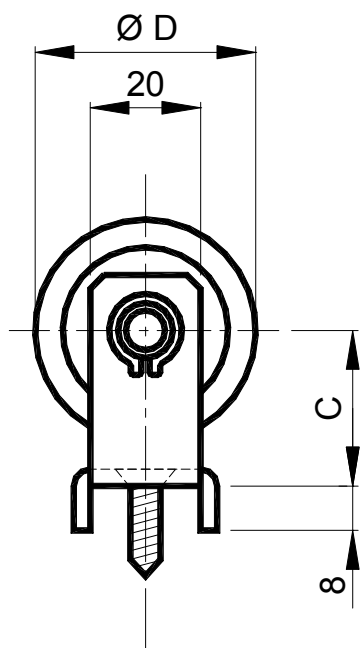
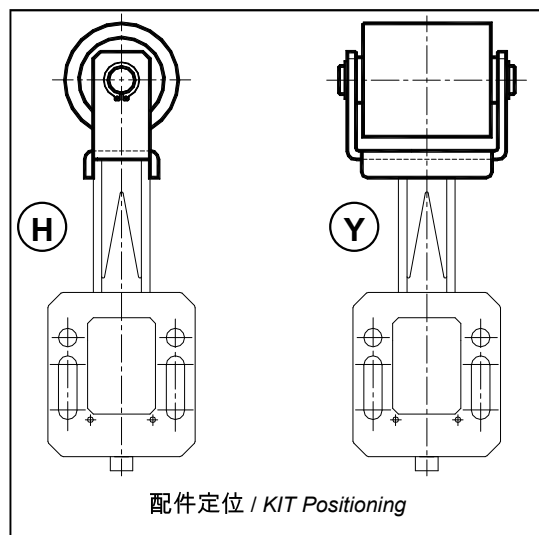

聚酰胺滚轮 Rollerset in polyamid									镀锌钢滚轮 Rollerset in galvanized steel		
型号 Type	编号 N°	重量 Weight in Kg	A	B	C	ØD	L	尺寸 Size	型号 Type	编号 N°	重量 Weight in Kg
FP 10-1	BL010284	0.18	60	45	23	30	35	10	FU 10-1	BL010286	0.26
FP 20-1	BL010284	0.18	60	45	23	30	35	20	FU 20-1	BL010286	0.26
FP 20-2/3	BL010294	0.38	66	52	28	40	45	20	FU 20-2/3	BL010296	0.56
FP 30-2/3	BL010294	0.38	66	52	28	40	45	30	FU 30-2/3	BL010296	0.56