

链条张紧装置配套元件 / KIT for chain tighteners

链条张紧装置镀锌钢链轮 具国产轴承 – 型号: FN
 Sprocket wheelset with national bearing – Type: FN



配套元件由一个铝质支架和空转链轮组成。链轮由一个底部加大的轴承上模制的 nylon PA 6-30% FV 制的冠组成。所用螺栓为镀锌钢。工作速度 ≤60 米 / 分。链轮工作温度 ≤80°C。客户应指定安装方向 (H 或 Y)，否则将以操作方式 H 提供。

The KIT is made up by an aluminium fork with idle pinion. The pinion consists of a crown in galvanized steel installed on a enlarged bearing. The used bolts and nuts are in galvanized steel. Operating speed £60 m/min. Operating temperature of the pinion £80°C. Please specify the positioning (H or Y), otherwise it will be supplied with H execution.

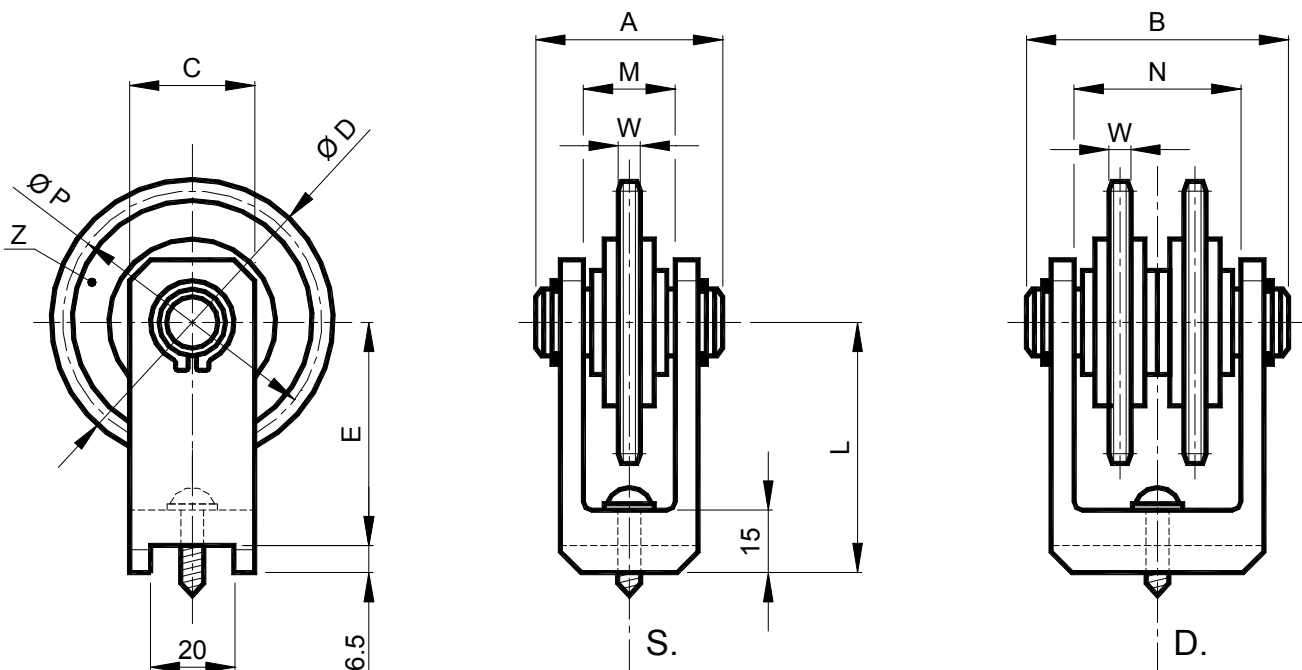
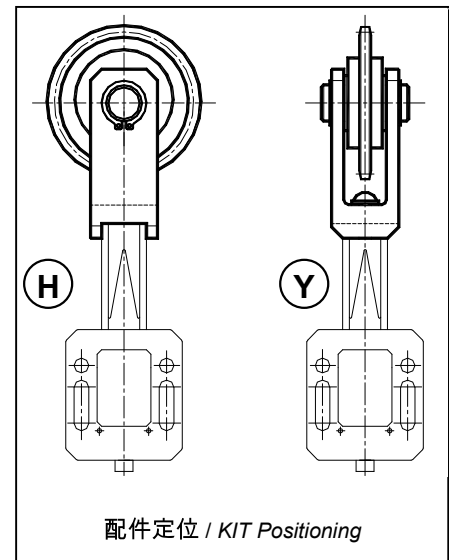

型号 Type	S 编号 N°	D 编号 N°	链条 Chain	尺寸 Size	Z	A	B	C	ØD	E	M	N	L	ØP	W	重量 Weight in Kg	
																S.	D.
FN 20-1	BL010260		3/8"x7/32"	20	21	39		30	68.0	53.5	19		60	63.90	5.3	0.29	
FN 30-1	BL010260	BL010266	3/8"x7/32"	30	21	39	60	30	68.0	53.5	19	37	60	63.90	5.3	0.29	0.52
FN 30-2	BL010262		1/2"x5/16"	30	18	39		30	77.8	53.5	19		60	73.14	7.2	0.36	
FN 30-3	BL010264		5/8"x3/8"	30	17	44		30	93.0	63.5	19		70	86.39	9.1	0.51	