

## 链条张紧装置配套元件 / KIT for chain tighteners

链条张紧装置塑料链轮 具国产轴承 – 型号: FC

Plastic sprocket wheelset with national bearing – Type: FC



配套元件由一个铝质支架和空转链轮组成。链轮由一个底部加大的轴承上模制的 nylon PA 6-30% FV 制的冠组成。所用螺栓为镀锌钢材质。工作速度 ≤60 米 / 分。链轮工作温度 ≤80°C。客户应指定安装定位 (H 或 Y)，否则将以操作方式 H 供货。

The kit is made up by an aluminium fork with idle pinion. The pinion consists of a nylon PA 6-30% FV crown installed on an enlarged bearing. The used bolts and nuts are in galvanized steel. Operating speed ≤60 m/min. Operating temperature of the pinion ≤80°C. Please specify the positioning (H or Y), otherwise it will be supplied with H execution.

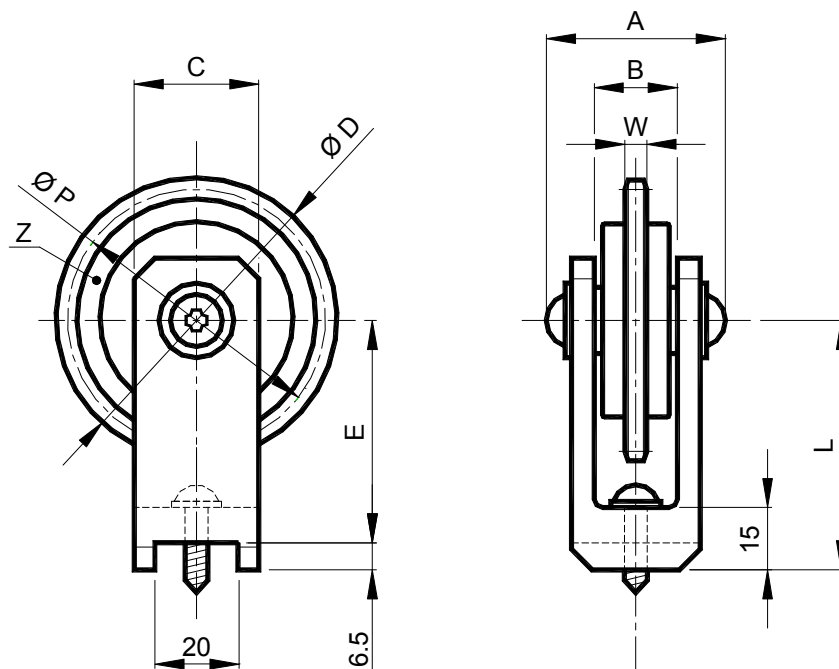
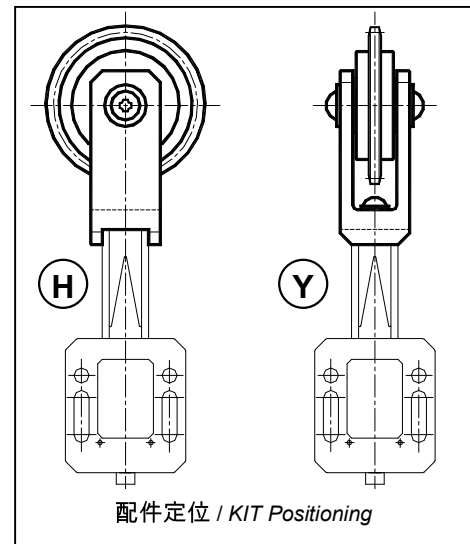

型号 Type	编号 N°	链条 Chain	尺寸 Size	Z	A	B	C	∅D	E	L	∅P	W	重量 Weight in Kg
FC 10-1	BL010250	3/8"x7/32"	10	21	42	19	30	68.0	53.5	60	63.90	5.3	0.10
FC 20-1	BL010250	3/8"x7/32"	20	21	42	19	30	68.0	53.5	60	63.90	5.3	0.10
FC 20-2	BL010252	1/2"x5/16"	20	18	42	19	30	77.8	53.5	60	73.14	7.2	0.18
FC 30-2	BL010252	1/2"x5/16"	30	18	42	19	30	77.8	53.5	60	73.14	7.2	0.18
FC 20-3	BL010254	5/8"x3/8"	20	17	47	19	30	93.0	63.5	70	86.39	9.1	0.30
FC 30-3	BL010254	5/8"x3/8"	30	17	47	19	30	93.0	63.5	70	86.39	9.1	0.30