

Tendeur Asso type **AF** / Asso Tensioner type **AF**

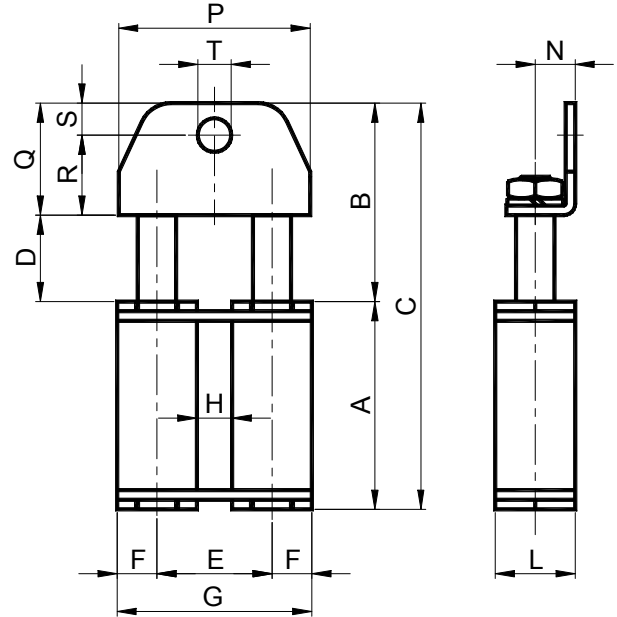

Élément tendeur à double colonne. Les sections carrées sont en aluminium, les jonctions, les colonnes et les bouchons sont en acier zingué, les bagues sont en laiton et la bride en acier zingué.

Tensioner element with double pin. The square bodies are made in aluminium; the junctions, the pins and the caps are in galvanized steel. The bushings are in brass. The bracket is in galvanized steel.



Type Type	Code n°	A	B	C	D	E	F	G	H	L	N	P	Q	R	S	ØT	V	Z	New.	Poids Weight [Kg]	Type Type	Code n°
AF1-8	AS010024	65	62	127	2	36	12	61	11	25	12.5	60	35	25	10	8.5	24	/	0-280	0.40	AFB1-8	AS010028
AF1-10	AS010025	65	62	127	2	36	12	61	11	25	12.5	60	35	25	10	10.5	24	/	0-280	0.40	AFB1-10	AS010029
AF1-16	AS010026	65	62	127	2	36	12	61	11	25	12.5	60	35	25	10	16	24	/	0-280	0.40	AFB1-16	AS010030
AF2-10	AS010035	79	85	164	3	42.	15	72.	12.	30	15	70	50	38	12	10.5	27	/	0-420	0.70	AFB2-10	AS010039
AF2-12	AS010036	79	85	164	3	42.	15	72.	12.	30	15	70	50	38	12	12.5	27	/	0-420	0.70	AFB2-12	AS010040
AF2-16	AS010037	79	85	164	3	42.	15	72.	12.	30	15	70	50	38	12	16.5	27	/	0-420	0.70	AFB2-16	AS010041
AF3-14	AS010047	100.5	102	202.5	42	49.5	17.5	84.5	14.5	35	20	80	60	46	14	M14	/	7.1	0-800	1.25	AFB3-14	AS010053
AF3-16	AS010048	100.5	102	202.5	42	49.5	17.5	84.5	14.5	35	20	80	60	46	14	M16	/	7.1	0-800	1.25	AFB3-16	AS010054
AF3-20	AS010049	100.5	102	202.5	42	49.5	17.5	84.5	14.5	35	20	80	60	46	14	M20	/	7.1	0-800	1.25	AFB3-20	AS010055

Tendeur Asso type **AFB** / Asso Tensioner type **AFB**
avec vis de pré-tension/ with preloading screw

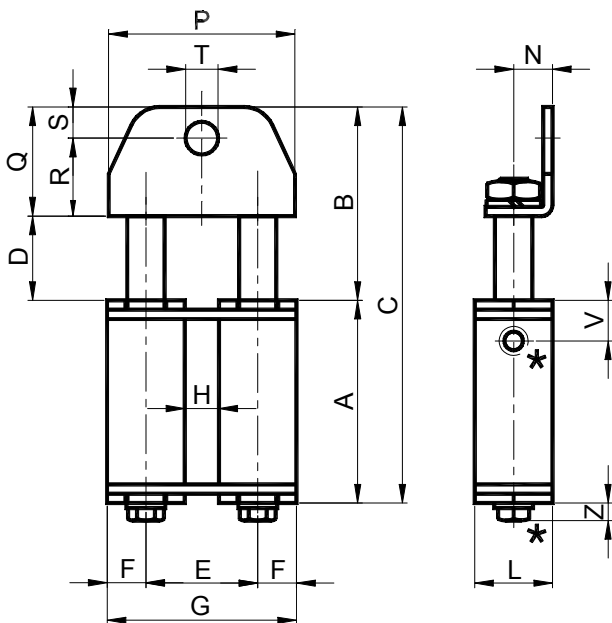

Élément tendeur à double colonne. Les sections carrées sont en aluminium, les jonctions, les colonnes et les bouchons en acier zingué. L'élément tendeur AFB a une vis de pré-tension (vis STEI (N) taille 1 et 2 et une vis TE (Z) taille 3) pour faciliter les opérations de montage.

Tensioner element with double pin. The square bodies are made in aluminium; the junctions, the pins and the caps are in galvanized steel. The bushings are in brass. The AFB tensioner element has a preloading screw (STEI screw (N) in the sizes 1 and 2; TE screw (Z) in the size 3) to make more easy the assembly operations.

* Vis de pré-tension/ Preloading screw