

张紧装置附件 型号 PH / Accessories for chain tighteners type PH



具底部扩大轴承的钢制链轮。

工作速度 ≤ 60 m/min。

工作温度 $\leq 100^\circ\text{C}$ 。

The pinion is made of steel with enlarged bearing.

Operating speed ≤ 60 m/min.

Operating temperature $\leq 100^\circ\text{C}$ 。

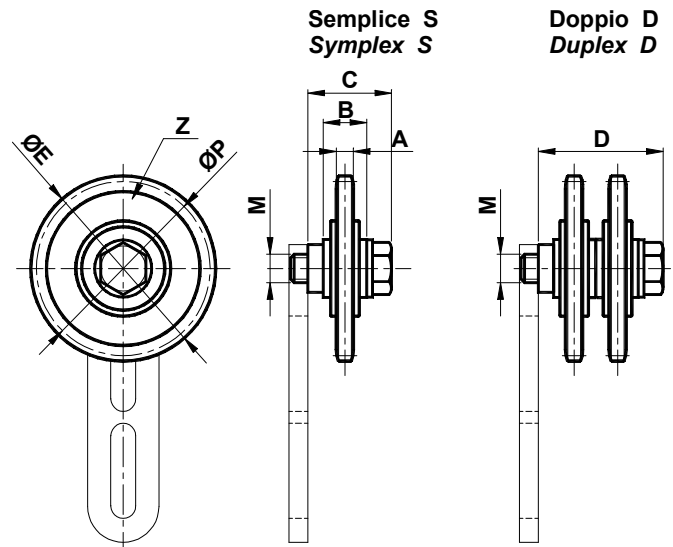

型号 Type	编号 S	编号 D	A	B	C	D	ØE	M	ØP	Z	张紧组件 Tension Elements	重量 Weight in kg	
												S	D
PH1-3/8"	AS010815	AS010825	5.3	18.3	35.3	53.6	68.0	M10	63.90	21	1-10	0.25	0.40
PH1-1/2"	AS010816	AS010826	7.2	18.3	35.3	53.6	77.8	M10	73.14	18	1-10	0.35	0.60
PH2-5/8"	AS010817	AS010827	9.1	18.3	38.8	57.1	93.0	M12	86.39	17	2-12	0.50	0.88
PH2-3/4"	AS010818	AS010828	11.1	18.3	38.8	57.1	99.8	M12	91.63	15	2-12	0.65	1.15
PH2-1"	AS010819	AS010829	16.2	17.7	43.7	75.4	109.0	M16	98.14	12	2-16	0.80	1.50

张紧装置附件 型号 CH / Accessories for chain tighteners type CH



具标准轴承的钢制链轮。

工作温度 $\leq 100^\circ\text{C}$ 。

工作速度 ≤ 60 m/min。

The pinion is made of steel with standard bearing.

Operating temperature $\leq 100^\circ\text{C}$ 。

Operating speed ≤ 60 m/min。

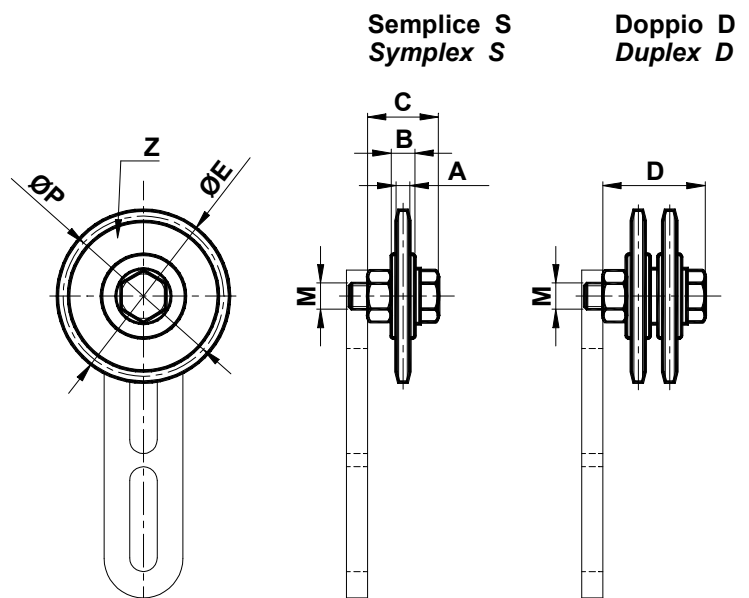

型号 Type	编号 S	编号 D	A	B	C	D	ØE	M	ØP	Z	张紧组件 Tension Elements	重量 Weight in kg	
												S	D
CH1-3/8"	AS010835	AS010845	5.3	9	28	39	49.3	M10	45.81	15	1-10	0.10	0.22
CH1-1/2"	AS010836	AS010846	7.2	9	28	41	65.5	M10	61.09	15	1-10	0.19	0.36
CH2-5/8"	AS010837	AS010847	9.1	12	34.5	51.5	83.0	M12	76.36	15	2-12	0.35	0.58
CH2-3/4"	AS010838	AS010848	11.	12	34.5	54	99.8	M12	91.63	15	2-12	0.55	0.98
CH2-1"	AS010839	AS010849	16.	15	38	70	117.0	M16	106.12	13	2-16	1.00	1.58