

**皮带张紧装置配套元件 / KIT for belt-tighteners**

在支架上的钢制滚轮 – 型号: **2RAU** / 在支架上的聚酰胺滚轮 – 型号: **2RAP**  
Roller set in steel – Type: **2RAU** / Roller set in polyamide – Type: **2RAP**



**2RAU**



**2RAP**

**材料 2RAU:** 支架、轴承、中心轴、垫圈和滑轮均为钢制。

**2RAP:** 支架、轴承、中心轴、垫圈为钢制，滚轮为黑色聚酰胺 PA6+MoS。

**处理 2RAU:** 支架为烤炉涂漆，金属部分为镀锌钢。

**2RAP:** 支架为烤炉涂漆，金属部分为镀锌钢，滚轮车削 1.6。

**应用** 配 ZZ 润滑轴承的滚轮。

**MATERIALS 2RAU:** Fork, bearings, pin, spacers, roller made of steel.  
**2RAP:** Fork, bearings, pin, spacers made of steel, roller made of black polyamide PA6+MoS.

**TREATMENTS 2RAU:** Fork oven painted, metallic components made of galvanized steel  
**2RAP:** Fork oven painted, metallic components made of galvanized steel, The roller is turned 1.6.

**USE** Roller with ZZ greased bearings.

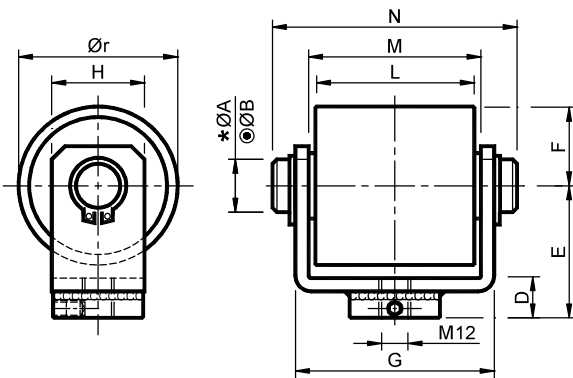

\*ØA : 用于钢制滚轮 / For roller made of steel

○ ØB : 用于聚酰胺滚轮 / For roller made of polyamide

钢制滚轮 Roller set in steel													聚酰胺滚轮 Roller set in polyamide			
型号 Type	编号 N°	* ØA	○ ØB	D	E	F	G	H	L	M	N	Ør	型号 Type	编号 N°	重量 Weight in Kg	
															2RAU	2RAP
2RAU 4	TB002052	16	12	15	50	30	75	35	60	65	85	60	2RAP 4	TB002062	1.16	0.65
2RAU 5	TB002053	20	20	20	65	40	111	45	90	95	121.5	80	2RAP 5	TB002063	2.98	1.70
2RAU 6	TB002054	20	20	20	70	45	156	45	135	140	167	90	2RAP 6	TB002064	5.80	2.49

工作区 Working field				工作区 Working field			
型号 Type	Ø 滚轮 Roller	最高转数 Max rpm	轴承 Bearing	型号 Type	Ø 滚轮 Roller	最高转数 Max rpm	轴承 Bearing
2RAU 4	60	9500	6304	2RAP 4	60	6000	6301
2RAU 5	80	6500	6306	2RAP 5	80	5000	6304
2RAU 6	90	6500	6306	2RAP 6	90	4500	6304

在表中描述的转数为近似的。其应用根据使用方式、运转率及工作条件而评估。

The rpm indicated in the chart is approximate. The application must be considered according to the type of use, the service factor and the working conditions.