

## 链条张紧装置配套元件 / KIT for chain tighteners

聚乙烯滑块 – 型号: VF / Polyethylene sliding block – Type: VF

配套元件由高分子密度聚乙烯滑块和不锈钢螺栓组成。工作速度  $\leq 20$  米 / 分。滑块工作温度  $\leq 70^\circ\text{C}$ 。具半圆形轮廓的滑块 V 适用于小轴距和在室外使用。客户应指定安装方向 (H 或 Y)，否则将以操作方式 H 供货。

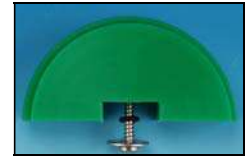

The KIT is made up by a polyethylene sliding block with high molecular density with bolts and nuts in stainless steel. Operating speed  $\leq 20$  m/min. Sliding block operating temperature  $\leq 70^\circ\text{C}$ . It is suitable for reduced interaxis and for use in outside environment. Please specify the positioning (H or Y), otherwise it will be supplied with H execution.

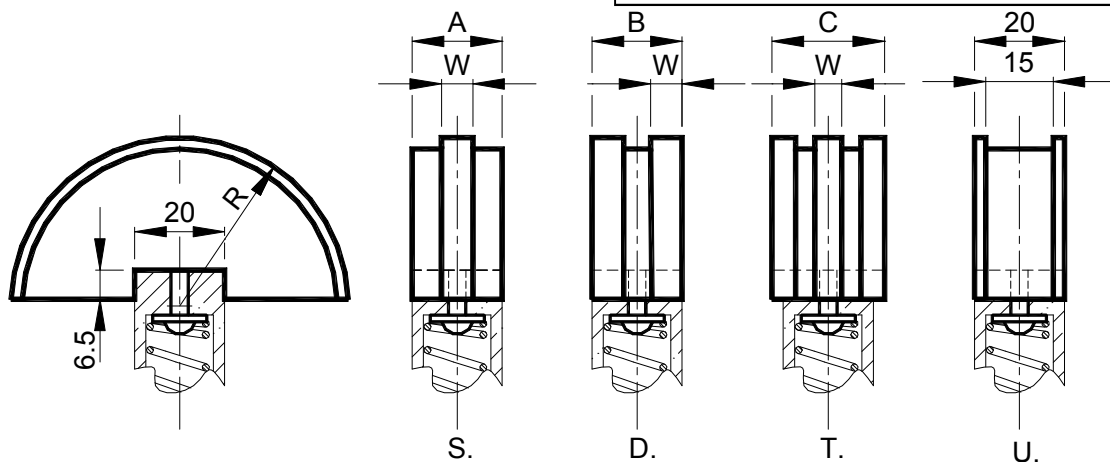
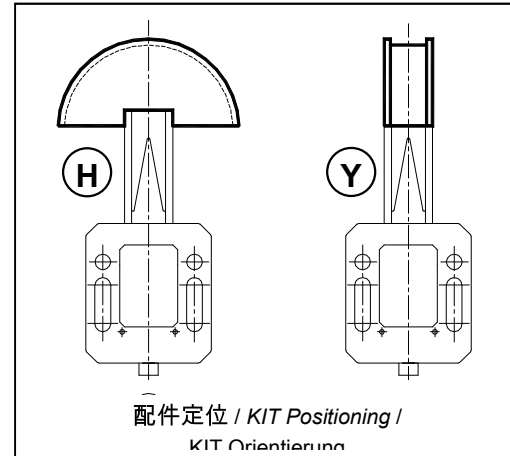

轮廓 U 用于宽度至 15 mm 的链条 / U Profile for chains with widths till 15 mm

型号 Type	S 编号 N°	D 编号 N°	T 编号 N°	U 编号 N°	链条 Chain	尺寸 Size	R	A	B	C	W	重量 Weight in Kg			
												S.	D.	T.	U.
VF 10-A	BL010172			BL010170	6 mm	10	37.5	20			2.3	0.03		0.03	
VF 10-0	BL010174	BL010190		BL010170	8 mm	10	37.5	20	20		2.5	0.03	0.03	0.03	
VF 20-0			BL010210		8 mm	20	37.5			20	2.5			0.04	
VF 30-0			BL010210		8 mm	30	37.5			20	2.5			0.04	
VF 10-1	BL010176	BL010192		BL010170	3/8"x7/32"	10	37.5	20	20		5	0.03	0.03	0.03	
VF 20-1	BL010176	BL010192	BL010212	BL010170	3/8"x7/32"	20	37.5	20	20	25	5	0.03	0.03	0.04	
VF 30-1			BL010212		3/8"x7/32"	30	37.5			25	5			0.04	
VF 20-2	BL010178	BL010194			1/2"x5/16"	20	37.5	20	20		7	0.03	0.04		
VF 30-2	BL010178	BL010194			1/2"x5/16"	30	37.5	20	20		7	0.03	0.04		
VF 20-3	BL010180				5/8"x3/8"	20	40	20			9	0.04			
VF 30-3	BL010180	BL010196			5/8"x3/8"	30	40	20	25		9	0.04	0.08		
VF 30-4	BL010182				3/4"x7/16"	30	40	20			11	0.05			