

ARCO упругие элементы – тип: **AB (±40°)** / **ARCO Elastic elements – Type: AB (±40°)**

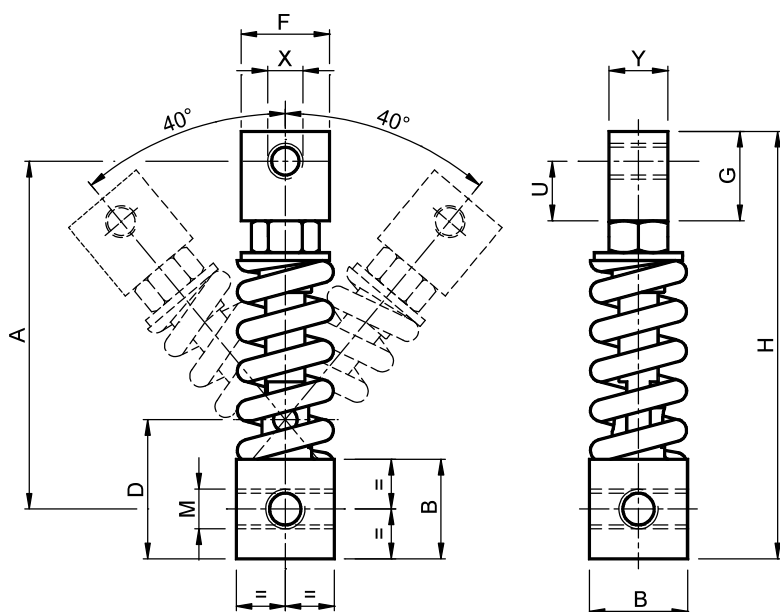

МАТЕРИАЛЫ: сталь. Поворотный палец изготовлен из латуни.

ОБРАБОТКА: белая оцинковка.

ИСПОЛЬЗОВАНИЕ: угол поворота ± 40°.

Рабочая температура от -30°C до +120°C.

MATERIALS Steel. Rotation pin made of brass.

TREATMENTS White galvanization.

USE Rotation angle ± 40°.

Working temperature from -30°C to +120°C.

±40°		A	B	D	F	G	H	M	U	X	Y	Усилие, Н 0° ÷ 40°	Вес в кг
Тип Type	Код №												
AB 10-8	AR070280	80	25	35	20	30	102.5	M8	20	M8	15	0 ÷ 90	0.24
AB 10-10	AR070285	80	25	35	20	30	102.5	M8	20	M10	15	0 ÷ 90	0.24
AB 20-10	AR070290	100	25	35	20	30	122.5	M10	20	M10	15	0 ÷ 135	0.31
AB 20-16	AR070295	100	25	35	30	30	122.5	M10	20	M16	15	0 ÷ 135	0.33
AB 30-10	AR070300	100	25	35	20	30	122.5	M12	20	M10	15	0 ÷ 275	0.31
AB 30-16	AR070305	100	25	35	30	30	122.5	M12	20	M16	15	0 ÷ 275	0.33
AB 40-12	AR070310	130	35	50	30	35	160	M16	22.5	M12	20	0 ÷ 750	0.80
AB 40-16	AR070315	130	35	50	30	35	160	M16	22.5	M16	20	0 ÷ 750	0.78
AB 50-16	AR070320	175	50	70	45	45	215	M20	30	M16	30	0 ÷ 1400	2.77
AB 50-20	AR070325	175	50	70	45	45	215	M20	30	M20	30	0 ÷ 1400	2.75
AB 60-20	AR070330	220	70	95	50	50	270	M24	35	M20	35	0 ÷ 2360	6.30

ARCO упругие элементы – тип: **ABN ($\pm 90^\circ$)** / **ARCO Elastic elements** – Type: **ABN ($\pm 90^\circ$)**

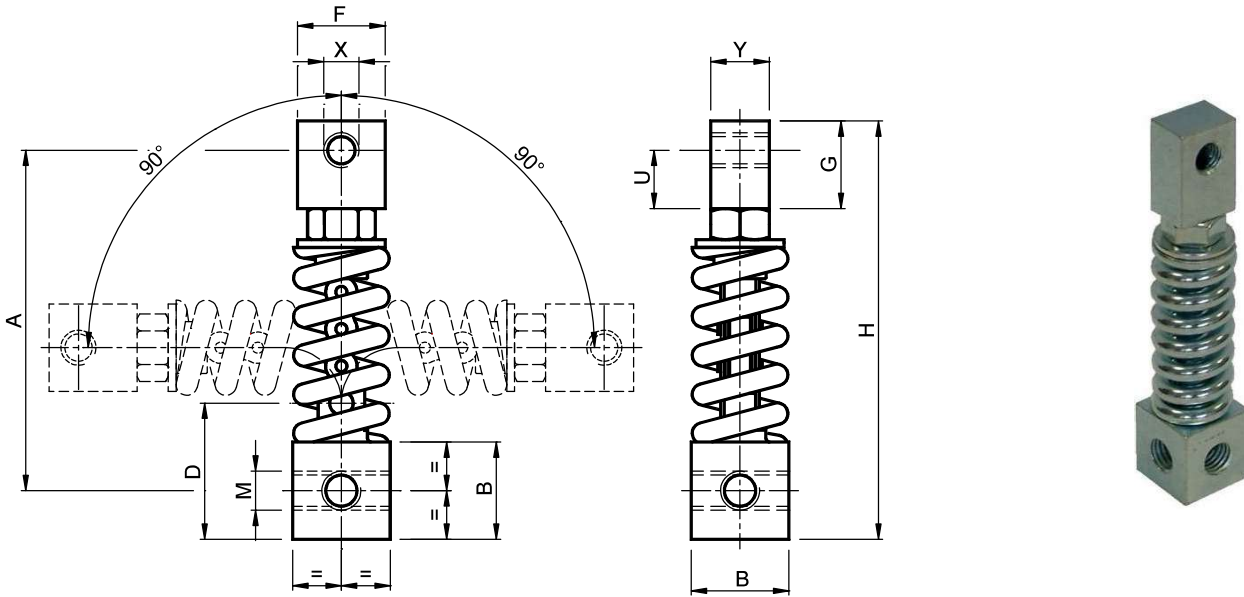

МАТЕРИАЛЫ: сталь.
ОБРАБОТКА: белая оцинковка.
ИСПОЛЬЗОВАНИЕ: угол поворота $\pm 90^\circ$.
 Рабочая температура от -30°C до $+120^\circ\text{C}$.

MATERIALS Steel.
TREATMENTS White galvanization.
USE Rotation angle $\pm 90^\circ$.
 Working temperature from -30°C to $+120^\circ\text{C}$.

$\pm 90^\circ$													
Тип Type	Код №	A	B	D	F	G	H	M	U	X	Y	Усилие, Н 0 \div 90 $^\circ$	Вес в кг
ABN 10-8	AR070350	80	25	35	20	30	102.5	M8	20	M8	15	0 \div 90	0.24
ABN 10-10	AR070355	80	25	35	20	30	102.5	M8	20	M10	15	0 \div 90	0.24
ABN 20-10	AR070360	100	25	35	20	30	122.5	M10	20	M10	15	0 \div 135	0.31
ABN 20-16	AR070365	100	25	35	30	30	122.5	M10	20	M16	15	0 \div 135	0.33
ABN 30-10	AR070370	100	25	35	20	30	122.5	M12	20	M10	15	0 \div 275	0.31
ABN 30-16	AR070375	100	25	35	30	30	122.5	M12	20	M16	15	0 \div 275	0.33
ABN 40-12	AR070380	130	35	50	30	35	160	M16	22.5	M12	20	0 \div 750	0.80
ABN 40-16	AR070385	130	35	50	30	35	160	M16	22.5	M16	20	0 \div 750	0.78
ABN 50-16	AR070390	175	50	70	45	45	215	M20	30	M16	30	0 \div 1400	2.77
ABN 50-20	AR070395	175	50	70	45	45	215	M20	30	M20	30	0 \div 1400	2.75
ABN 60-20	AR070400	220	70	95	50	50	270	M24	35	M20	35	0 \div 2360	6.30