

张紧装置附件 型号 SPL / Accessories for chain tighteners type SPL



具底部扩大轴承的钢制链轮。

工作速度  $\leq 60$  m/min。

工作温度  $\leq 100^\circ\text{C}$ 。

Steel pinion with enlarged bearing.  
Operating speed  $\leq 60$  m/min.  
Operating temperature  $\leq 100^\circ\text{C}$ .

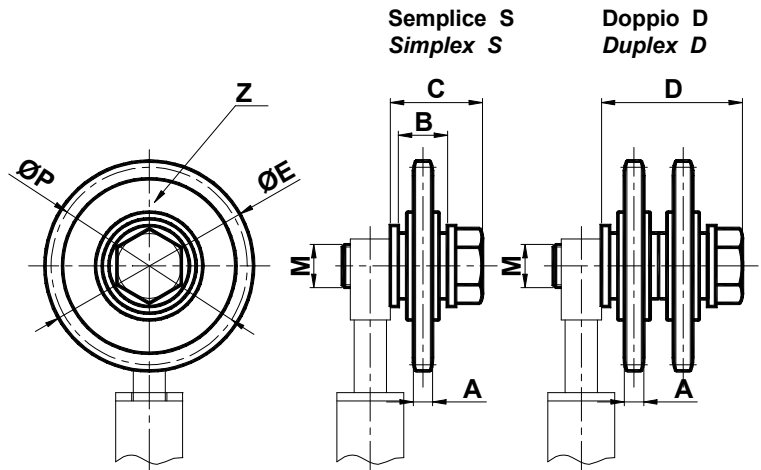

型号 Type	编号 S	编号 D	A	B	C	D	ØE	M	ØP	Z	重量 Weight in kg	
											S	D
SPL1-2 3/8"	AS010690	AS010705	5.3	18.3	37.3	55.6	68.0	M16	63.90	21	0.2	0.35
SPL1-2 1/2"	AS010691	AS010706	7.2	18.3	37.3	55.6	77.8	M16	73.14	18	0.3	0.55
SPL3 5/8"	AS010694	AS010709	9.1	18.3	42.3	60.6	93.0	M16	86.39	17	0.45	0.8
SPL3 3/4"	AS010695	/	11.1	18.3	42.3	/	99.8	M16	91.63	15	0.6	/

张紧装置附件 型号 SCL / Accessories for chain tighteners type SCL



具标准轴承的钢制链轮。

工作温度  $\leq 100^\circ\text{C}$ 。

工作速度  $\leq 60$  m/min。

Steel pinion with standard bearing.  
Operating temperature  $\leq 100^\circ\text{C}$ .  
Operating speed  $\leq 60$  m/min.

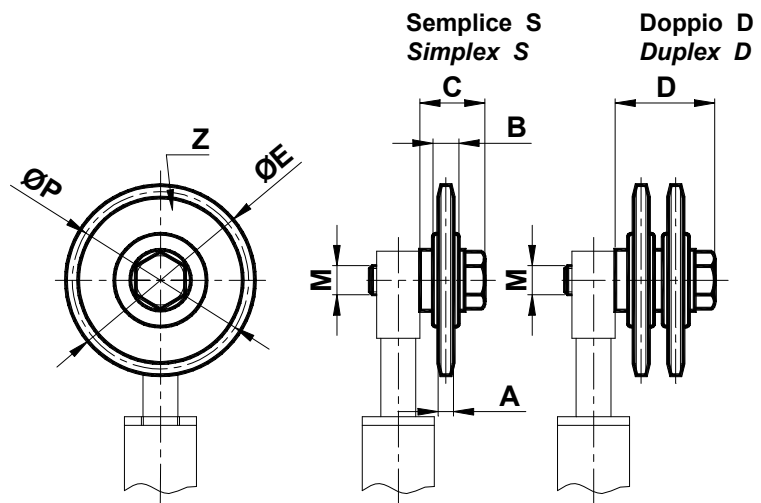

型号 Type	编号 S	编号 D	A	B	C	D	ØE	M	ØP	Z	重量 Weight in kg	
											S	D
SCL1-2 3/8"	AS010720	AS010735	5.3	9	26	37	49.3	M10	45.81	15	0.10	0.22
SCL1-2 1/2"	AS010721	AS010736	7.2	9	28	41	65.5	M10	61.09	15	0.19	0.36
SCL3 5/8"	AS010724	AS010739	9.1	12	34.5	39.5	83.0	M12	76.36	15	0.35	0.58
SCL3 3/4"	AS010725	/	11.1	12	34.5	/	99.8	M12	91.63	15	0.55	/