

皮带张紧装置配套元件 / KIT for belt-tighteners

聚酰胺滚轮- 型号: RP / 镀锌钢滚轮 - 型号: RU

Roller set in polyamide – Type: RP / Roller set in galvanized steel – Type: RU

- 用于聚酰胺滚轮螺钉 “M”
- For polyamide-roller screw “M”

- \* 用于钢制滚轮螺钉 “P”
- \* Rollerset galvanized steel “P”

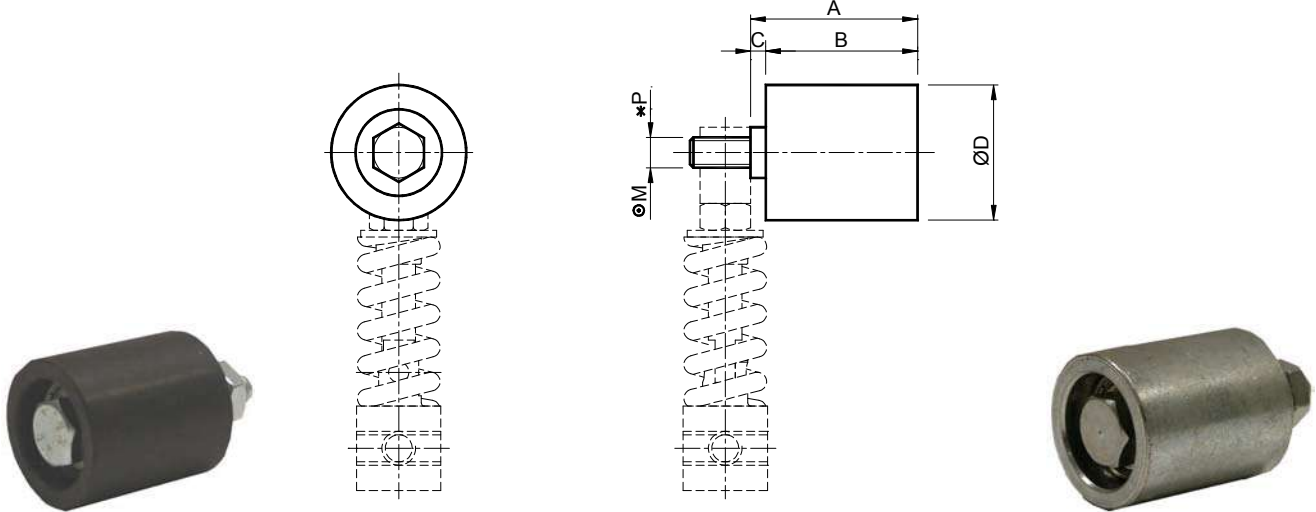

**材料** 滚轮为黑色聚酰胺 PA6+MoS，轴承和垫圈为钢制。

**处理** 金属部分为镀锌钢，滚轮车削 1.6。轴承润滑。

**应用** 皮带张紧装置用滚轮。滚轮工作温度 ≤ 70°C。

**MATERIALS** Roller made of polyamide PA6+MoS, bearings and spacers made of steel.

**TREATMENTS** Metallic components made of galvanized steel. The roller is turned 1.6. Greased bearings.

**USE** Belt tensioning. Operating temperature ≤ 70°C.

**材料** 滚轮、轴承和垫圈均为钢制。

**处理** 金属部分为镀锌钢。轴承润滑。

**应用** 皮带张紧装置用滚轮。滚轮工作温度 ≤ 100°C。

**MATERIALS** Roller bearings and spacers made of steel.

**TREATMENTS** Metallic components made of galvanized steel. Greased bearings.

**USE** Belt tensioning. Operating temperature ≤ 100°C.

◦M : 用于聚酰胺滚轮 / For polyamide roller

\*P : 用于钢制滚轮 / For steel roller

型号 Type	编号 N°	重量 Weight in Kg	A	B	C	D	M ◦	P *	尺寸 SIZE	型号 Type	编号 N°	重量 Weight in Kg
RP 1	RE011090	0.08	38	35	3	30	M8	M8	10	RU 1	AR070870	0.16
RP 2/3	RE011092	0.18	51	45	6	40	M10	M10	20/30	RU 2/3	AR070872	0.37
RP 4	RE011094	0.40	68	60	8	60	M12	M16	40	RU 4	AR070874	0.85
RP 5	RE011096	1.20	99	90	9	80	M20	M20	50	RU 5	AR070876	2.09
RP 6	RE011098	1.70	142	135	7	90	M20	M20	60	RU 6	AR070878	2.44

工作区 Working field				工作区 Working field			
型号 Type	∅ 滚轮 Roller	最高转数 Max rpm	轴承 Bearing	型号 Type	∅ 滚轮 Roller	最高转数 Max rpm	轴承 Bearing
RP 1	30	8000	608	RU 1	30	15000	608
RP 2/3	40	8000	6200	RU 2/3	40	12000	6200
RP 4	60	6000	6304	RU 4	60	9500	6304
RP 5	80	5000	6304	RU 5	80	6500	6306
RP 6	90	4500	6304	RU 6	90	6500	6306

在表中描述的转数为近似的。其应用根据使用方式、运转率及工作条件而评估。

The rpm indicated in the chart is approximate. The application must be considered according to the type of use, the service factor and the working conditions.