

Asso 张紧装置 型号 SA / Asso Tensioner type SA

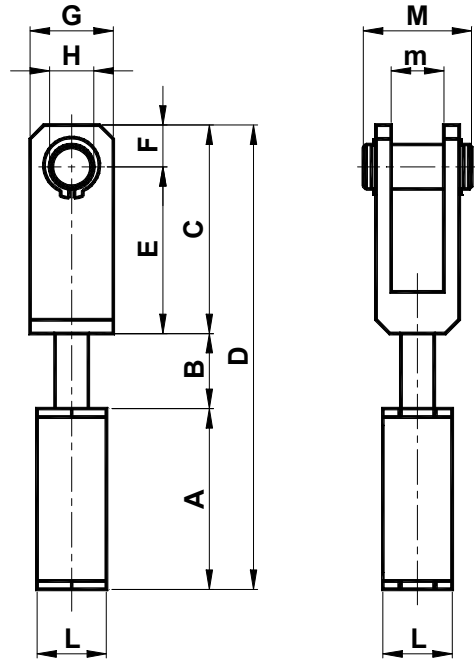

具单柱张紧装置组件。方形主体为铝制；方柱和帽为镀锌钢制。

轴衬为黄铜制。支架可为铝制或镀锌钢制。

Tensioner element with single pin. The square body is made in aluminium; the pin and the cap are in galvanized steel. The bushing is in brass. The fork can be in aluminium or painted steel.

型号 Type	编号	A	B	C	D	E	F	G	H	L	M	m	N	P	Newton	重量 Weight in kg	型号 Type	编号
SA1/0	AS010489	59	27	75	161	60	15	30	16	25	40	19	21	/	0-140	0.31	SAB1/0	AS010509
SA2/0	AS010490	71	35	75	181	60	15	30	16	30	40	19	23	/	0-140	0.40	SAB2/0	AS010510
SA2/1	AS010491	71	35	85	191	70	15	30	16	30	45	19	23	/	0-210	0.44	SAB2/1	AS010511
SA2/2	AS010492	71	35	75	181	60	15	30	16	30	60	37	23	/	0-210	0.45	SAB2/2	AS010512
SA2/3	AS010493	71	35	85	191	70	15	30	16	30	65	37	23	/	0-400	0.50	SAB2/3	AS010513
SA3/4	AS010494	92.5	42	85	219.5	70	15	35	16	35	80	56	/	7.1	0-400	1.03	SAB3/4	AS010514
SA3/5	AS010495	92.5	42	95	229.5	77.5	17.5	40	20	35	45	19	/	7.1	0-400	0.72	SAB3/5	AS010515
SA3/6	AS010496	92.5	42	95	229.5	77.5	17.5	40	20	35	77	51	/	7.1	0-400	1.30	SAB3/6	AS010516
SA3/7	AS010497	92.5	42	95	229.5	77.5	17.5	40	20	35	110	80	/	7.1	0-400	1.63	SAB3/7	AS010517

Asso 张紧装置 型号 SAB / Asso Tensioner type SAB

具预加负荷用螺钉 / with preloading screw

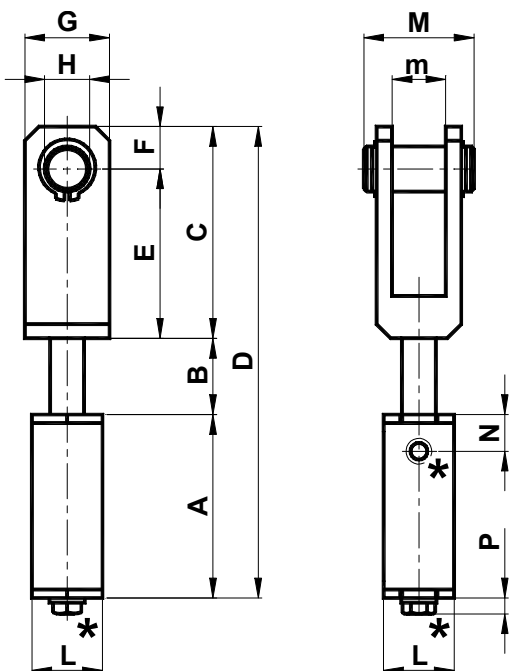

具单柱张紧装置组件。方形主体为铝制；方柱和帽为镀锌钢制。轴衬为黄铜制。支架可为铝制或镀锌钢制。SAB 张紧装置组件具预加负荷用螺钉(尺寸 1 和 2, STEI (N)螺钉；尺寸 3, TE (P) 螺钉)，以便简化安装操作。

Tensioner element with single pin. The square body is made in aluminium; the pin and the cap are in galvanized steel. The bushing is in brass. The fork can be in aluminium or painted steel. The SAB tensioner element has a preloading screw (STEI screw (N) in the sizes 1 and 2; TE screw (P) in the size 3) to make more easy the assembly operations.

* 预加负荷用螺钉 / Preloading screw