

张紧装置附件 型号 TL / Accessories for chain tighteners type TL



具半圆形轮廓滑块，适用于小轴距和靠近链轮的安装。

材料：高分子密度聚乙烯。

工作速度  $\leq 20$  m/min。工作温度  $\leq 70^\circ\text{C}$ 。

Semi-circular sliding block suitable for reduced interaxis or for installation closed to the pinion. Material: Polyethylene with high molecular density.

Operating speed  $\leq 20$  m/min.

Sliding block operating temperature  $\leq 70^\circ\text{C}$ .

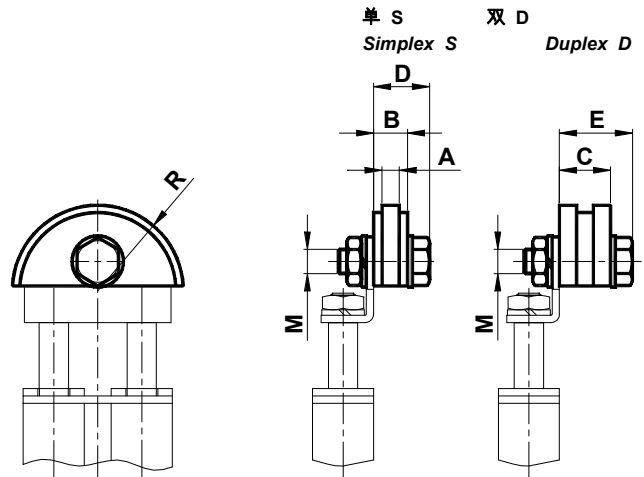

型号 Type	编号 S	编号 D	A	B	C	D	E	M	R	重量 Weight [Kg]	
										S	D
TL1 3/8"	AS010351	AS010366	5	10	18	19	27	M10	35	0.07	0.08
TL1 1/2"	AS010352	AS010367	7	14	20.5	23	29.5	M10	35	0.09	0.10
TL2 5/8"	AS010354	AS010369	9	16.5	25	25.5	34	M10	45	0.11	0.12
TL2 3/4"	AS010355	AS010370	11	17.5	30	26.5	39	M10	45	0.11	0.13
TL3 1"	AS010356	AS010371	16	18	47	28.5	57.5	M12	55	0.19	0.27

皮带拉紧装置附件 / Accessories for belt-tighteners

聚酰胺滚轮 - 型号 DP

Rollerset of polyamid - Type DP

\* 具螺钉 M / With M screw



镀锌钢滚轮 - 型号 DA

Rollerset of galvanized steel - Type DA

# 具螺钉 P / With P screw

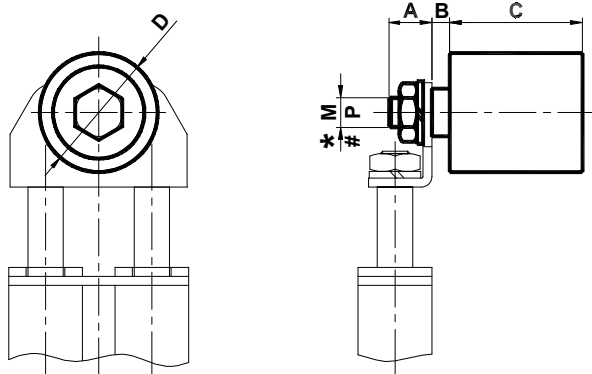

塑性材料制 DP 滚轮，在润滑轴承上安装。

工作温度  $\leq 70^\circ\text{C}$ 。

The roller DP is in plastic installed on greased bearings. Roller operating temperature  $\leq 70^\circ\text{C}$ .

镀锌钢制 DP 滚轮，在润滑轴承上安装。

工作温度  $\leq 100^\circ\text{C}$ 。

The DA roller is in galvanized steel installed on greased bearings. Operating temperature  $\leq 100^\circ\text{C}$ .

型号 Type	编号 n°	重量 Weight [Kg]	A	B	C	ØD	*M	#P	张紧元件 Tension Elements	型号 Type	编号 n°	重量 Weight [Kg]
DP30	CE070300	0.08	13	3	35	30	M 8	M 8	1	DA30	CE070285	0.16
DP40	CE070302	0.18	16	6	45	40	M10	M10	1-2	DA40	CE070287	0.37
DP60	CE070304	0.40	21	8	60	60	M12	M16	3	DA60	CE070289	0.85