

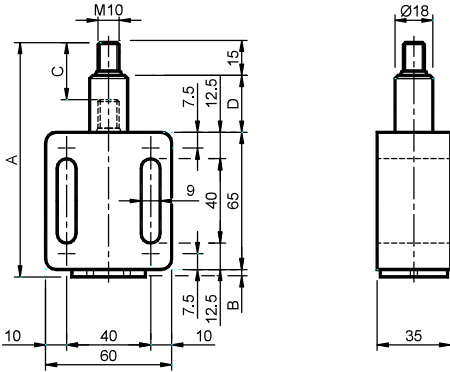

TEN BLOC 弹簧式弹性组件 – 型号: TN 及 TNa
TEN BLOC Elastic spring elements – Type: TN and TNa

TN – TNa 10/20/30



 **材料** 铝制主体配黄铜轴承。圆柱、堵盖、圆筒和弹簧均为钢制。

处理 喷砂铝，局部为镀锌钢，粗加工弹簧涂油。

应用 弹簧式弹性组件不具备预加压系统。链条或皮带的游隙通过弹簧的运动自动补偿。

C: 张紧装置行程。

 **MATERIALS** Body made of aluminium with brushing made of brass. Column, cap, cylinders and spring made of steel.

TREATMENTS Sandblasted aluminium, components made of galvanized steel, greased raw spring.

USE Elastic spring Element without preloading systems. The recover of chain- or belt- slack takes place automatically through the spring action.

C: Tightener travel.



TN – TNa 40/50

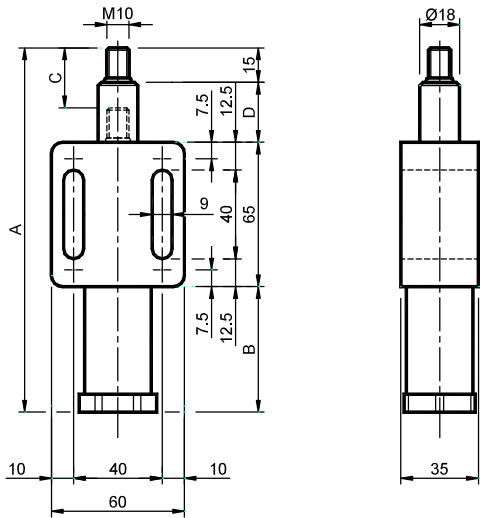

TN – TNa 60/70/80/90

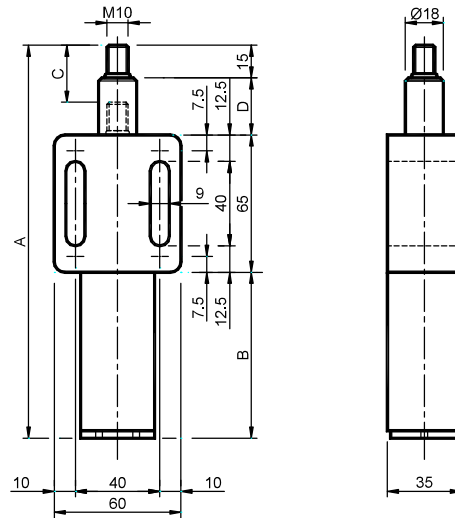

型号 TN – Type TN:

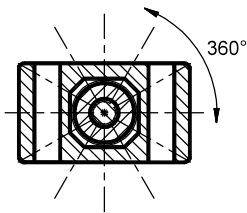

圆柱有可能绕其自身的轴扭转以便对张紧装置配件进行 360° 的调整。

The column HAS the possibility to rotate on its own axis to allow an adjustment on the 360° of the chaintightener kit.

型号 TNa – Type TNa:

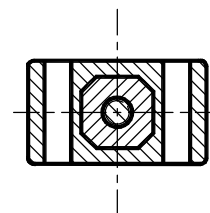

圆柱不可能绕其自身的轴扭转。这个组件尤其适合与张紧装置配件一并使用。

The column HAS NOT the possibility to rotate on its own axis. This element is especially useful with the kits belt tighteners.



型号 Type	编号 N°	A	B	C	D	Newton	型号 Type	编号 N°	重量 - Weight in Kg
TN 10	TB013000	110.5	3.5	26	27	30 ÷ 100	TNa 10	TB013040	0.40
TN 20	TB013001	110.5	3.5	25	27	60 ÷ 170	TNa 20	TB013041	0.40
TN 30	TB013002	110.5	3.5	24	27	90 ÷ 250	TNa 30	TB013042	0.40
TN 40	TB013003	135.5	28.5	27	27	100 ÷ 400	TNa 40	TB013043	0.47
TN 50	TB013004	180.0	58.0	42	42	180 ÷ 700	TNa 50	TB013044	0.60
TN 60	TB013005	210.5	88.5	42	42	220 ÷ 1000	TNa 60	TB013045	0.85
TN 70	TB013006	235.5	113.5	42	42	340 ÷ 1500	TNa 70	TB013046	1.00
TN 80	TB013007	235.5	113.5	42	42	400 ÷ 2000	TNa 80	TB013047	1.00
TN 90	TB013008	280.5	158.5	42	42	500 ÷ 2500	TNa 90	TB013048	1.28