

Separation block for roller side guide (double type) - Part. T42

Pattino per guida laterale doppia (due vie) - Part. T42

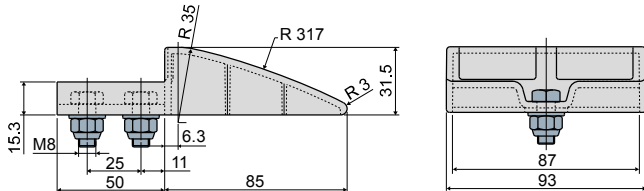

Type/Tipo	Code/Codice	Material/Materiale
T42	CP000497	polyethylene/polietilene
T42A	CPC00497	PA + auto-lubricant additive PA + additivo autolubrificante

UK MATERIALS: Separation block in polyethylene or in polyamide with auto-lubricating additive; bolts and nuts in stainless steel AISI 304. **FEATURES:** To be used at the end of the side guides (Part.T07, Q74, T26, Q77, T56), to help the arrival of the products. The version with auto-lubricating additive guarantees maximum smoothness of the product. Supplied complete with bolts and nuts.

IT MATERIALI: Pattino in polietilene o PA + additivo autolubrificante; bulloneria in acciaio inox AISI 304. **CARATTERISTICHE:** Da utilizzare alle estremità delle guide laterali (Part.T07, Q74, T26, Q77, T56), per favorire l'arrivo dei prodotti. La versione con additivo autolubrificante garantisce la massima scorrevolezza del prodotto. Fornito completo di bulloneria.

Application example
Esempio di applicazione

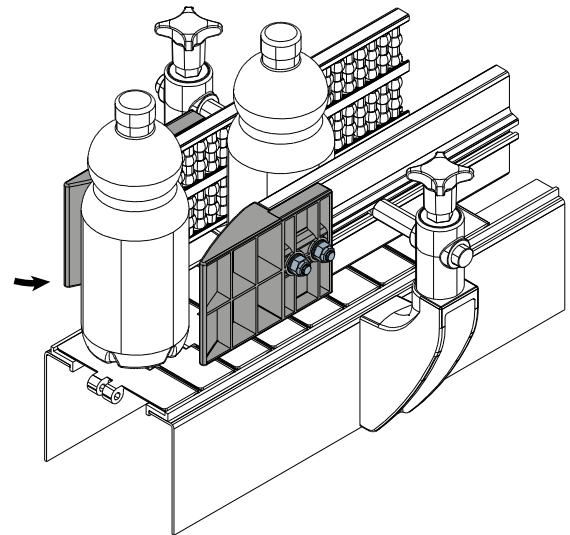
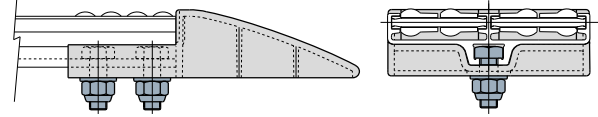

Separation block for roller central guide (quadruple type) - Part. T43

Pattino per guida centrale (quattro vie) - Part. T43

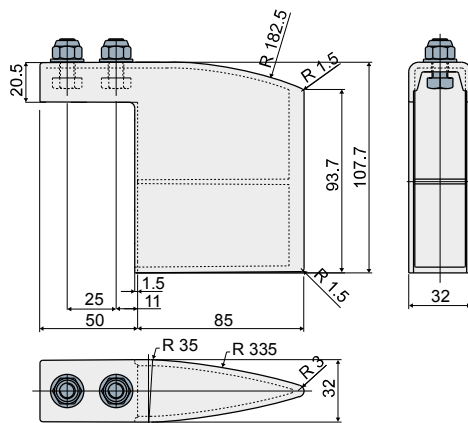

Type/Tipo	Code/Codice	Material/Materiale
T43	CP000498	polyethylene/polietilene
T43A	CPC00498	PA + auto-lubricant additive PA + additivo autolubrificante

UK MATERIALS: Separation block in polyethylene or in polyamide with auto-lubricating additive; bolts and nuts in stainless steel AISI 304. **FEATURES:** To be used at the end of the central guides (Part.T19, Q76, T28, Q79, T58), to help the arrival of the products. The version with auto-lubricating additive guarantees maximum smoothness of the product. Supplied complete with bolts and nuts.

IT MATERIALI: Pattino in polietilene o PA + additivo autolubrificante; bulloneria in acciaio inox AISI 304. **CARATTERISTICHE:** Da utilizzare alle estremità delle guide centrali (Part.T19, Q76, T28, Q79, T58), per favorire l'arrivo dei prodotti. La versione con additivo autolubrificante garantisce la massima scorrevolezza del prodotto. Fornito completo di bulloneria.

Application example
Esempio di applicazione

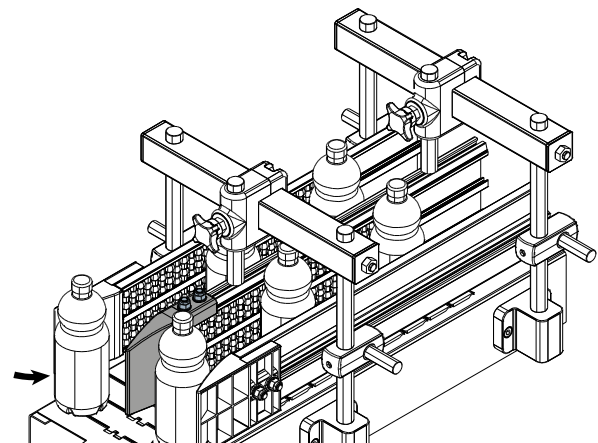
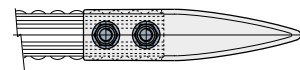
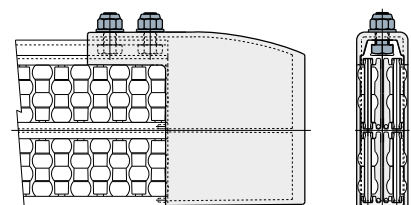

Suitable for applications which require maximum smoothness.
Indicato per applicazioni che richiedono la massima scorrevolezza.