

Separation block for roller side guide (single type) - Part. T40

Pattino per guida laterale (una via) - Part. T40

Application example
Esempio di applicazione

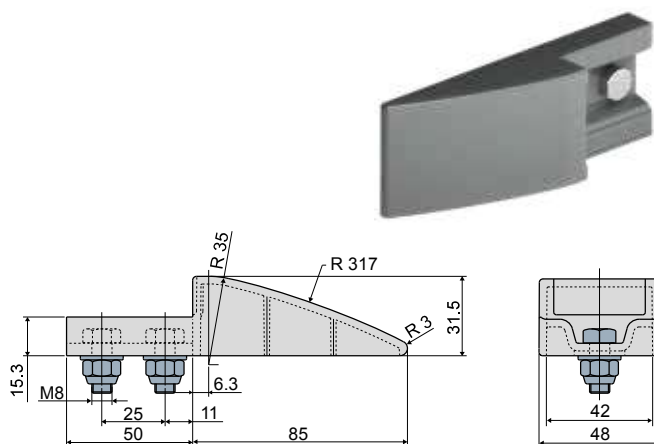
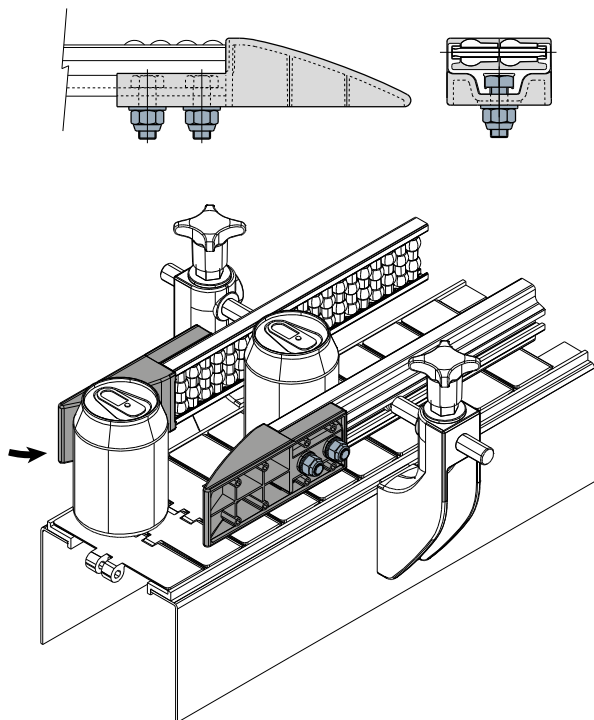

Type/Tipo	Code/Codice	Material/Materiale
T40	CP000495	polyethylene/polietilene
T40A	CPA00495	PA + auto-lubricant additive PA + additivo autolubrificante

UK MATERIALS: Separation block in polyethylene or in polyamide with auto-lubricating additive; bolts and nuts in stainless steel AISI 304. **FEATURES:** To be used at the end of the side guides (Part.T06, Q68, T25, Q67, T55, Q64), to help the arrival of the products. The version with auto-lubricating additive guarantees maximum smoothness of the product. Supplied complete with bolts and nuts.

IT MATERIALI: Pattino in polietilene o PA + additivo autolubrificante; bulloneria in acciaio inox AISI 304. **CARATTERISTICHE:** Da utilizzare alle estremità delle guide laterali (Part.T06, Q68, T25, Q67, T55, Q64), per favorire l'arrivo dei prodotti. La versione con additivo autolubrificante garantisce la massima scorrevolezza del prodotto. Fornito completo di bulloneria.

Separation block for roller central guide (double type) - Part. T41

Pattino per guida centrale (due vie) - Part. T41

Application example
Esempio di applicazione

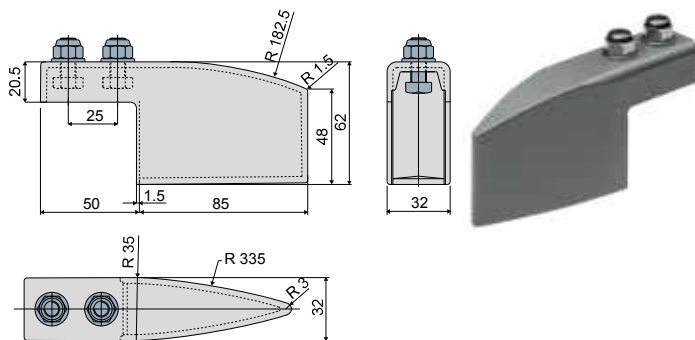
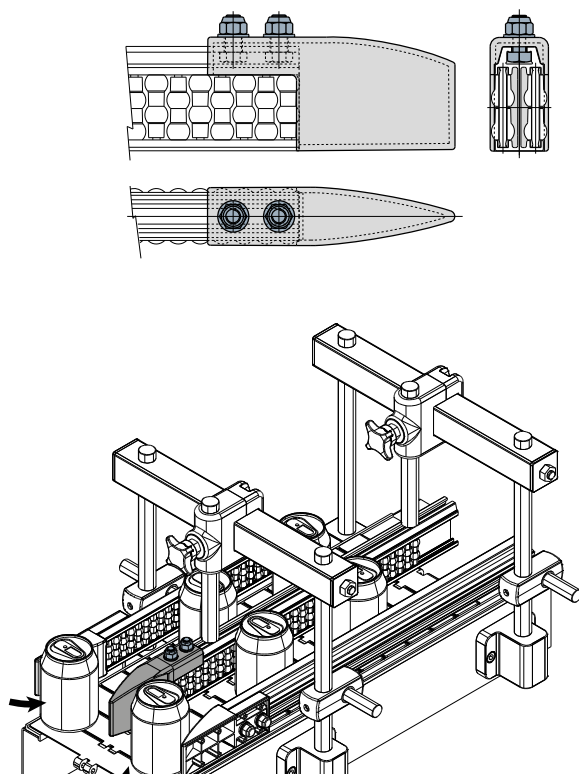

Type/Tipo	Code/Codice	Material/Materiale
T41	CP000496	polyethylene/polietilene
T41A	CPA00496	PA + auto-lubricant additive PA + additivo autolubrificante

UK MATERIALS: Separation block in polyethylene or in polyamide with auto-lubricating additive; bolts and nuts in stainless steel AISI 304. **FEATURES:** To be used at the end of the central guides (Part.T08, Q75, T27, Q78, T57, Q80), to help the arrival of the products. The version with auto-lubricating additive guarantees maximum smoothness of the product. Supplied complete with bolts and nuts.

IT MATERIALI: Pattino in polietilene o PA + additivo autolubrificante; bulloneria in acciaio inox AISI 304. **CARATTERISTICHE:** Da utilizzare alle estremità delle guide centrali (Part.T08, Q75, T27, Q78, T57, Q80), per favorire l'arrivo dei prodotti. La versione con additivo autolubrificante garantisce la massima scorrevolezza del prodotto. Fornito completo di bulloneria.

Suitable for applications which require maximum smoothness.
Indicato per applicazioni che richiedono la massima scorrevolezza.