

KIT pour tendeurs de courroie / KIT for belt-tighteners

Rouleau en acier zingué sur chape – Type: **RAU** / Rouleau en polyamide sur chape – Type: **RAP**
Roller set in galvanized steel – Type: **RAU** / Roller set in polyamide – Type: **RAP**

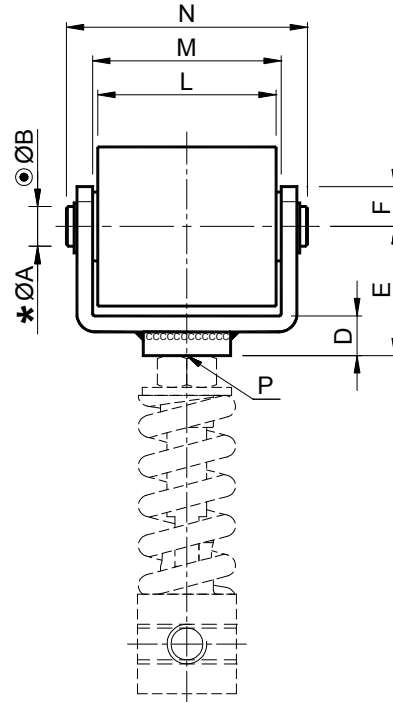
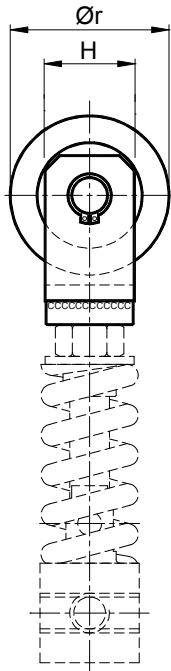

MATERIAUX RAU: Chape, roulements, pivot, entretoises et rouleau en acier.

RAP: Chape, roulements, pivot et entretoises en acier, rouleau en polyamide PA6+MoS noir

TRAITEMENTS RAU: Chape vernie au four, composants métalliques en acier zingué.

RAP: Chape vernie au four, composants métalliques en acier zingué, rouleau tourné 1.6.

UTILISATION Rouleau avec roulements ZZ lubrifiés.

MATERIALS RAU: Fork, bearings, pin, spacers, roller made of steel.

RAP: Fork, bearings, pin, spacers made of steel, roller made of black polyamide PA6+MoS.

TREATMENTS RAU: Fork oven painted, metallic components made of galvanized steel

RAP: Fork oven painted, metallic components made of galvanized steel, the roller is turned 1.6.

USE Roller with ZZ greased bearings.

* ØA : Pour rouleau en acier / For roller made of steel

○ ØB : Pour rouleau en polyamide / For roller made of polyamide

Rouleau en acier Roller set in steel														Rouleau en polyamide Roller set in polyamide			
Type Type	Code n°	*	○	D	E	F	H	L	M	N	P	Ør	Taille Size	Type Type	Code n°	Poids Weight Kg	
		ØA	ØB													RAU	RAP
RAU 1	AR070902	8	8	15	35	15	20	35	43	60	M10	30	10	RAP 1	AR070886	0.26	0.18
RAU2/3	AR070904	10	10	15	40	20	25	45	50	68	M10	40	20/30	RAP2/3	AR070888	0.56	0.38
RAU 4	AR070906	16	12	15	50	30	35	60	65	85	M14	60	40	RAP 4	AR070890	1.36	1.15
RAU 5	AR070908	20	20	20	65	40	45	90	95	121.5	M20	80	50	RAP 5	AR070892	3.59	2.66
RAU 6	AR070910	20	20	20	70	45	45	135	140	167	M24	90	60	RAP 6	AR070894	5.95	4.35

Champ d'application Working field				Champ d'application Working field			
Type Type	Ø Rouleau Roller	Nombre de tours max Max rpm	Roulement Bearing	Type Type	Ø Rouleau Roller	Nombre de tours max Max rpm	Roulement Bearing
RAU 1	30	15000	608	RAP 1	30	8000	608
RAU 2/3	40	12000	6200	RAP 2/3	40	8000	6200
RAU 4	60	9500	6304	RAP 4	60	6000	6301
RAU 5	80	6500	6306	RAP 5	80	5000	6304
RAU 6	90	6500	6306	RAP 6	90	4500	6304

Le nombre de tours indiqué dans le tableau est approximatif. L'application doit être évaluée suivant l'utilisation, le facteur de service et les conditions de travail.

The rpm indicated in the chart is approximate. The application must be considered according to the type of use, the service factor and the working conditions.