

Cross clamp - Part. Q70
Morsetto a croce - Part. Q70

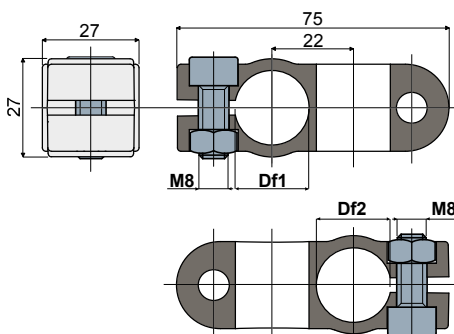

Version with bolts
Versione con bulloneria

Version without bolts
Versione senza bulloneria

Bore for pin of
Foro per perno da
Df1 Df2
round/tondo round/tondo
(mm) (mm)

Type/Tipo	Code/Codice	Type/Tipo	Code/Codice	Df1 (mm)	Df2 (mm)
Q70A	CPB00199	Q70D	CPB00202	16	16
Q70B	CPB00200	Q70E	CPB00203	16	20
Q70C	CPB00201	Q70F	CPB00204	20	20

UK MATERIALS: Clamp, bolts and nuts in stainless steel AISI 304.
FEATURES: Supplied with bolts and nuts.

IT MATERIALI: Morsetto e bulloneria in acciaio inox AISI 304.
CARATTERISTICHE: Fornito completo di bulloneria.

Application example
Esempio di applicazione

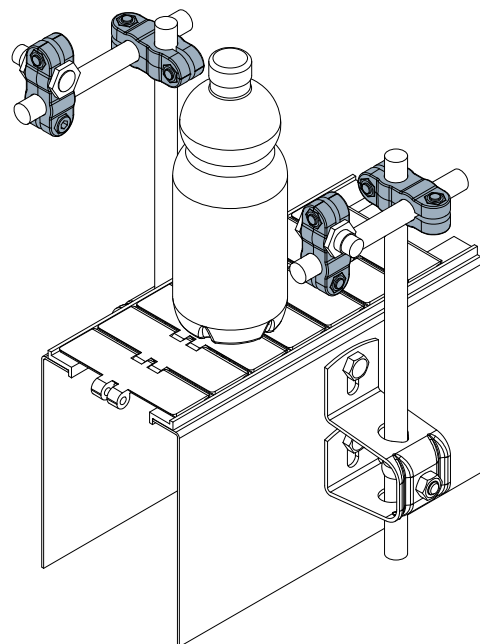

Guide rail clamp - Part. C31
Morsetto portaguida - Part. C31

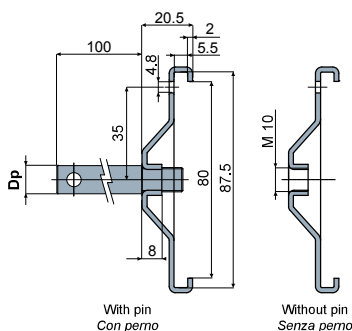
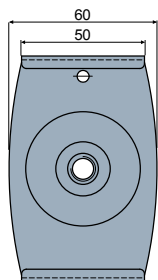

With pin
Con perno

Without pin
Senza perno

Dp
Pin diameter
Diámetro perno
(mm)

With pin
Con perno

Without pin
Senza perno

Dp Pin diameter Diámetro perno (mm)	Type/Tipo	Code/Codice	Type/Tipo	Code/Codice
12	C31A	CPA00217		
14	C31B	CPA00218	C31D	CPA00220
16	C31C	CPA00219		

UK MATERIALS: Clamp, threaded pin, washer and nut in stainless steel AISI 304.
FEATURES: Supplied with or without pin. To be used with side guide Part. C28.

IT MATERIALI: Morsetto, perno filettato, rosetta e dado in acciaio inox AISI 304.
CARATTERISTICHE: Fornito con perno di sostegno oppure senza perno. Da utilizzare con la guida laterale Part. C28.

Application example
Esempio di applicazione

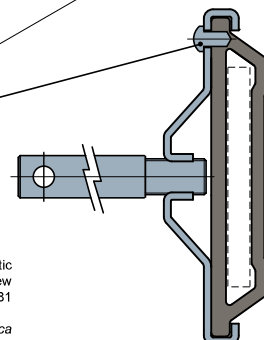
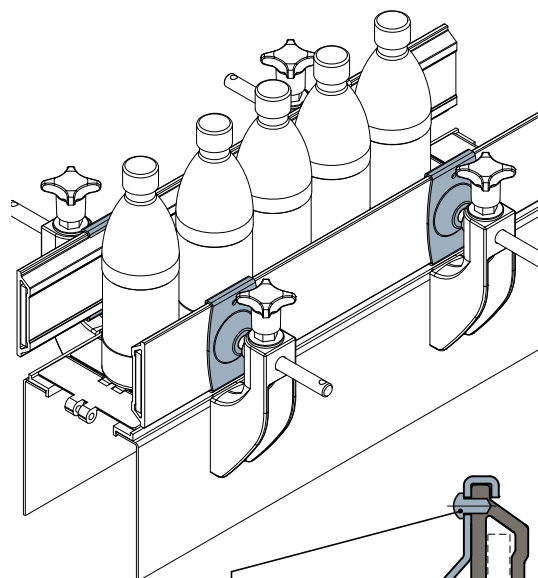

It is possible to fix the clamp to the plastic profile by using a self-tapping screw 4.8x9.5 DIN7981

Possibilità di fissaggio al profilo in plastica tramite vite autofilettante 4.8x9.5 DIN 7981.