

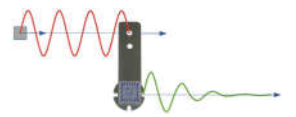

CRESA CIAO

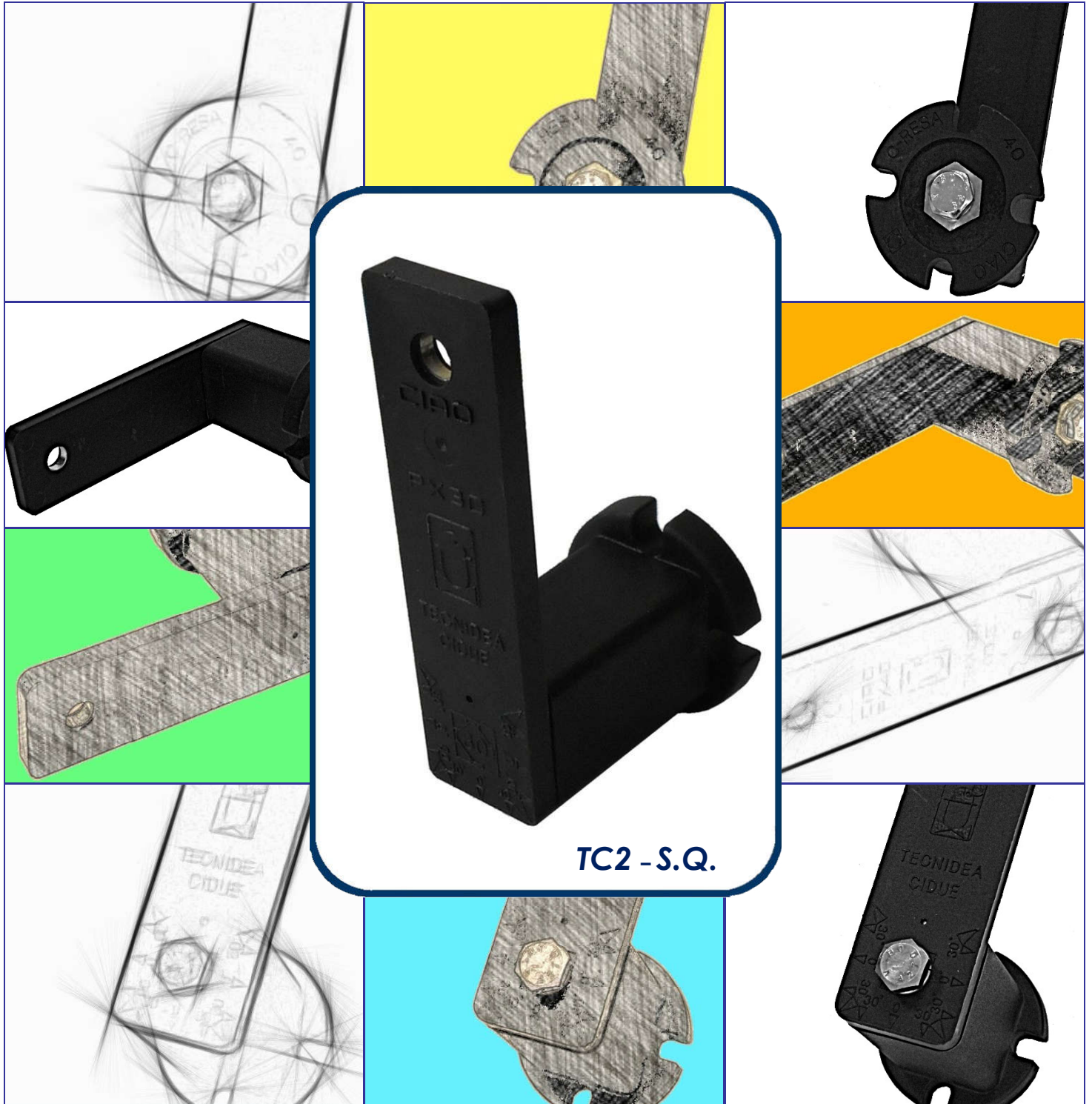

PATENTED TENSIONER UNITS



TC2 - S.Q.



GB

I



TECNIDEA CIDUE S.r.l.







PRODUCTION RANGE: / PANORAMICA PRODOTTI:

			
PX pag. D-3	PX-R pag. D-3	XVR pag. D-5	XOV pag. D-5
			
XRO pag. D-6	XZN pag. D-7	AZN pag. D-7	XZK pag. D-8
			
XRP pag. D-9	XRU pag. D-9	XPR pag. D-10	SN pag. D-10

CIAO ELASTIC ELEMENTS IN PLASTIC AND STAINLESS STEEL

 CIAO elastic elements are entirely manufactured in plastic and stainless steel; therefore, especially suitable for food - pharmaceutical industries as well as for all applications affected by corrosion problems. CIAO items are elastic elements with rotation operation. The elastic deformation of four cylinders made of natural rubber, lodged inside the place that result when two elements with square section are turned at an angle of 45° one to the other, produces high elasticity and high resistance to shocks, vibrations and oscillations. The available rotation angle is $\pm 30^\circ$, thereby enabling 30° elastic rotation clockwise and anticlockwise from the centre line (rest position). The special design guarantees silent performances, high reliability, it allows several advantageous installation solutions and solves easily application problems. These elements can be used in many fields and various applications: chain tensioners, belt tensioners, shock absorbers, vibration dampeners, downholders, decelerators, elastic support, etc. Product size and technical data are printed near each element. CIAO products have the advantage to be interchangeable with CRESA products, thanks to their load capacity and size. For the automatic rotation tensioners theory and assembly instructions see chapter C.

CIAO ELEMENTI ELASTICI IN PLASTICA ED INOX

 Gli elementi elastici CIAO sono costruiti interamente in materiale plastico ed acciaio INOX; quindi particolarmente utili nel settore alimentare – farmaceutico ed in tutte le applicazioni ove esistano problemi di ruggine. Gli articoli CIAO sono elementi elastici con funzionamento a rotazione. L'elevata elasticità e la grande capacità di assorbimento di urti, colpi, vibrazioni e oscillazioni è prodotta dalla deformazione elastica di quattro cilindri di gomma alloggiati nei vani risultanti dall'accoppiamento di due elementi a sezione quadrata ruotati di 45° l'uno rispetto all'altro. L'angolo di rotazione che può raggiungere è di $\pm 30^\circ$. Considerando la posizione di riposo come mezzeria, possiamo avere una rotazione elastica in senso orario di 30° e di 30° in senso antiorario. La particolare costruzione garantisce un funzionamento silenzioso, di grande affidabilità, permette innumerevoli vantaggiose soluzioni di montaggio ed inoltre risolve con semplicità i vari problemi applicativi. I settori di impiego sono molteplici e moltissime le applicazioni quali: tendicatena, tendicinghia, ammortizzatori, antivibranti, pressori, deceleratori, supporti elastici, ecc. Il dimensionamento e gli specifici dati tecnici di funzionamento dei prodotti, sono descritti a lato di ogni singolo particolare. I prodotti CIAO, inoltre offrono il vantaggio di essere intercambiabili con i prodotti CRESA, per capacità di carico e geometria. Per la teoria sui tenditori automatici a rotazione e per le istruzioni di montaggio si rimanda al capitolo C.

Plastic Tensioning elements – Type: **PX** / *Elementi tenditori in plastica* – Tipo: **PX**

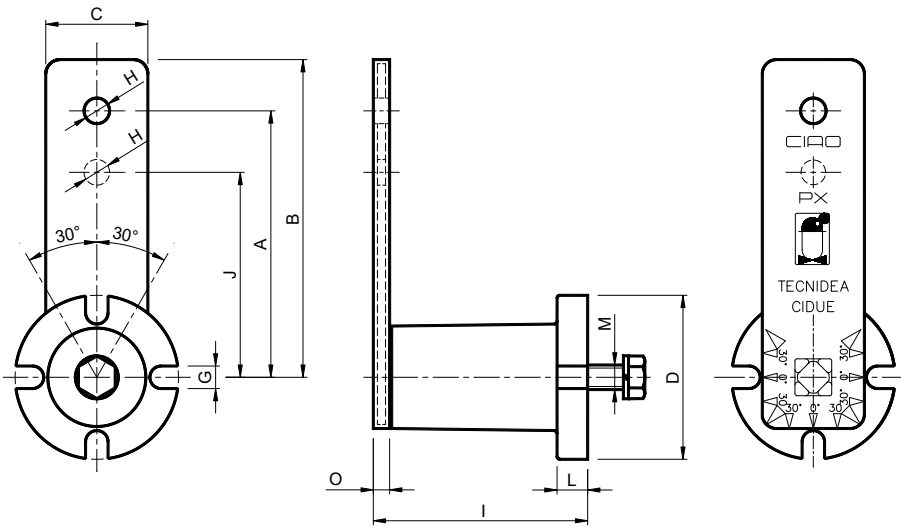

UK MATERIALS The body is made of plastic with a brass insert. The lever is made of plastic with steel rib. Stainless steel screws.
TREATMENTS The rib is galvanized.
USE Operating temperature from -35°C to +80°C.

IT MATERIALI Il corpo è in materiale plastico con inserto in ottone. La leva è in materiale plastico con nervatura in acciaio. Viti in acciaio inossidabile.
TRATTAMENTI La nervatura della leva è zincata.
IMPIEGO Temperatura di lavoro da -35°C a +80°C.



Type Tipo	Cod. N°	A	B	C	ØD	ØH	I	J	L	M	O	R	Newton	Newton	Weight Peso in [kg]	Type Tipo	Cod. N°	
													0°-30° Arm A Braccio A	0°-30° Arm J Braccio J				
PX 10	RE010910	80	90	24	40	8,5	52 ^{+1,5} _{-0,5}	60	6	M6x20	7	7,5	0+	90	0+	120	PX 10 R	RE010911
PX 20	RE010920	100	112	30	50	10,5	66 ^{+1,5} _{-0,5}	80	8	M8x25	8	9,2	0+	140	0+	175	PX 20 R	RE010921
PX 30	RE010930	100	115	36	60	10,5	79 ^{+1,5} _{-0,5}	80	10	M10x30	8	10,5	0+	340	0+	475	PX 30 R	RE010931
PX 40	RE010940	130	155	50	80	12,5	108 ^{+2,0} _{-1,0}	100	15	M12x40	10	10,5	0+	860	0+	1118	PX 40 R	RE010941



Plastic Tensioning elements – Type: **PX-R** / *Elementi tenditori in plastica* – Tipo: **PX-R**

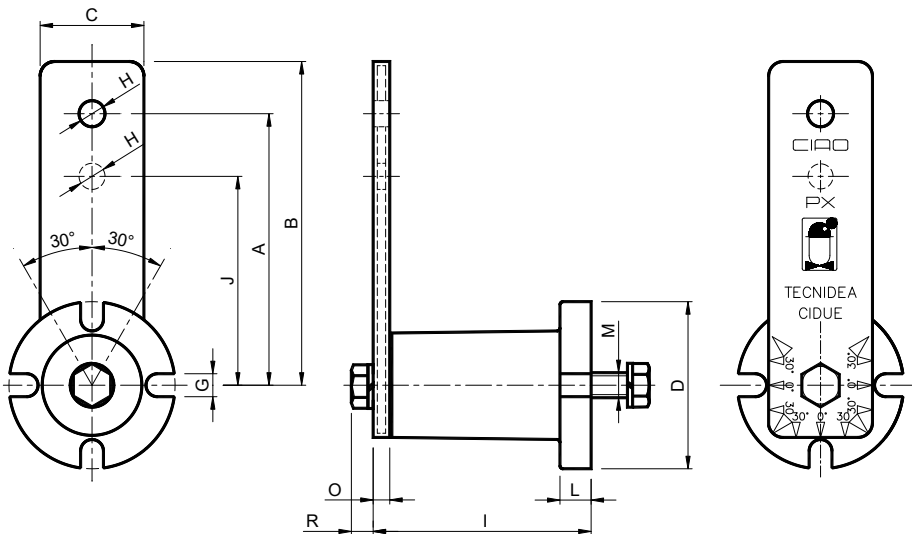

UK MATERIALS The body is made of plastic with a brass insert. The lever is made of plastic with steel rib. Stainless steel screws.
TREATMENTS The rib is galvanized.
USE Operating temperature from -35°C to +80°C.

IT MATERIALI Il corpo è in materiale plastico con inserto in ottone. La leva è in materiale plastico con nervatura in acciaio. Viti in acciaio inossidabile.
TRATTAMENTI La nervatura della leva è zincata.
IMPIEGO Temperatura di lavoro da -35°C a +80°C.



CHAIN – CATENA DIN 8187		Type – Tipo						Size Taglia	Type - Tipo		BELT
ISO	Pitch Passo	XVR Pag. D-5	XOV Pag. D-5	XRO Pag. D-6	XZN Pag. D-7	AZN Pag. D-7	XZK Pag. D-8		XRP Pag. D-9	XRU Pag. D-9	Max belt width Largh. max. cinghia
05-B1	8mm	XVR 10-0S		XRO 10-0S				10	XRP 1	XRU 1	30
06-B1	3/8"x7/32"	XVR 10-1S	XOV 10-1S	XRO 10-1S				10			
06-B1	3/8"x7/32"				XZN 20-1S	AZN 20-1S	XZK 20-1S	20			
06-B1	3/8"x7/32"				XZN 30-1S	AZN 30-1S	XZK 30-1S	30			
08-B1	1/2"x5/16"	XVR 20-2S	XOV 20-2S	XRO 20-2S				20	XRP 2/3	XRU 2/3	40
08-B1	1/2"x5/16"	XVR 30-2S	XOV 30-2S	XRO 30-2S	XZN 30-2S	AZN 30-2S	XZK 30-2S	30	XRP 2/3	XRU 2/3	40
10-B1	5/8"x3/8"	XVR 30-3S	XOV 30-3S	XRO 30-3S	XZN 30-3S	AZN 30-3S		30			
10-B1	5/8"x3/8"				XZN 40-3S	AZN 40-3S	XZK 40-3S	40	XRP 4	XRU 4	55
12-B1	3/4"x7/16"	XVR 30-4S	XOV 30-4S	XRO 30-4S				30			
12-B1	3/4"x7/16"	XVR 40-4S	XOV 40-4S	XRO 40-4S			XZK 40-4S	40			
16-B1	1"x17,02mm	XVR 40-5S		XRO 40-5S			XZK 40-5S	40			
05-B2	8mm	XVR 10-0D		XRO 10-0D				10			
06-B2	3/8"x7/32"	XVR 10-1D	XOV 10-1D	XRO 10-1D				10			
06-B2	3/8"x7/32"						XZK 20-1D	20			
06-B2	3/8"x7/32"						XZK 30-1D	30			
08-B2	1/2"x5/16"	XVR 20-2D	XOV 20-2D	XRO 20-2D				20			
08-B2	1/2"x5/16"	XVR 30-2D	XOV 30-2D	XRO 30-2D			XZK 30-2D	30			
10-B2	5/8"x3/8"	XVR 30-3D	XOV 30-3D	XRO 30-3D				30			
10-B2	5/8"x3/8"						XZK 40-3D	40			
12-B2	3/4"x7/16"	XVR 30-4D	XOV 30-4D	XRO 30-4D				30			
12-B2	3/4"x7/16"	XVR 40-4D	XOV 40-4D	XRO 40-4D			XZK 40-4D	40			
16-B2	1"x17,02mm	XVR 40-5D		XRO 40-5D			XZK 40-5D	40			
06-B3	3/8"x7/32"	XVR 20-1T		XRO 20-1T				20			
06-B3	3/8"x7/32"						XZK 30-1T	30			
08-B3	1/2"x5/16"	XVR 30-2T		XRO 30-2T				30			
08-B3	1/2"x5/16"						XZK 40-2T	40			
10-B3	5/8"x3/8"	XVR 40-3T		XRO 40-3T				40			
12-B3	3/4"x7/16"	XVR 40-4T		XRO 40-4T			XZK 40-4T	40			
16-B3	1"x17,02mm	XVR 40-5T		XRO 40-5T				40			

Blue codes s on request / Codici in blu a richiesta

HOW TO USE THE HOLE J IN PX AND PX-R / COME UTILIZZARE IL FORO J NEI PX E PX-R

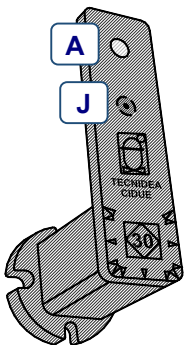

fig. 1

🇬🇧 The tensioner is provided with the "A" hole only. The "J" hole is indicated with a reference mark.
 🇮🇹 Il tenditore si presenta con il solo foro A. Il foro J è indicato con un centrino.

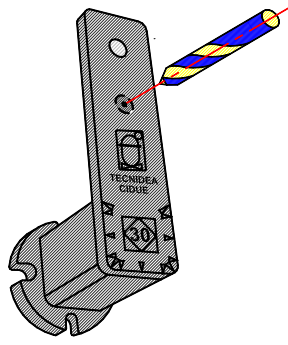

fig. 2

🇬🇧 With a simple drilling operation on the reference mark You can make the J hole.
 🇮🇹 Con una semplice operazione di foratura in corrispondenza del centrino si realizza il foro J.

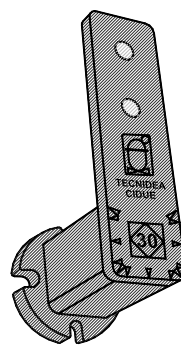

fig. 3

🇬🇧 Once removed the plastic, the hole is ready to be used.
 🇮🇹 Rimossa la plastica dal foro J, il foro risulta subito utilizzabile.

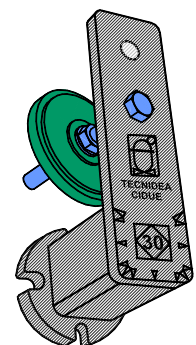
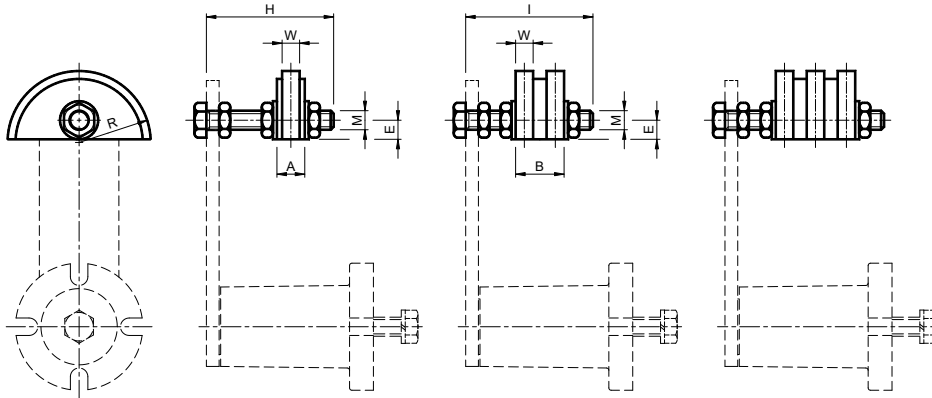

fig. 4

🇬🇧 The KIT assembly on the hole J is the same of the hole A.
 🇮🇹 Il montaggio del KIT sul foro J è il medesimo che per il foro A.

Polyethylene sliding block Type: **XVR / Pattino in polietilene – Tipo: XVR**



S.

D.

T.

On request
A richiesta

UK MATERIALS High molecular density polyethylene. Bolts and nuts are made of stainless steel.
USE Semi-circular sliding block suitable for reduced distance between centres or for installations close to the pinion. Operating speed ≤ 20 m/min. Operating temperature $\leq 70^\circ\text{C}$.

IT MATERIALI Polietilene ad alta densità molecolare. Bulloneria in acciaio inossidabile.
IMPIEGO Profilo semicircolare adatto per piccoli interassi o per montaggi vicino al pignone. Velocità di lavoro ≤ 20 m/min. Temperatura di lavoro $\leq 70^\circ\text{C}$.



Type Tipo	S Cod.N°	D Cod.N°	Chain Catena	Type Tipo	S Cod.N°	D Cod.N°	Size Taglia	A	B	E	G	H	I	M	P	Q	R	W	Weight Peso in [kg]	
																			S.	D.
XVR 10-0	RE011975	RE011995	05-B				10	10,0	12,0	10		45	45	M8			35	2,5	0,09	0,10
XVR 10-1	RE011976	RE011996	06-B	XOV 10-1	RE013001	RE013021	10	10,0	18,0	10	10,2	45	45	M8	75	40	35	5,0	0,09	0,10
XVR 20-2	RE011979	RE011999	08-B	XOV 20-2	RE013004	RE013024	20	14,0	20,5	10	13,9	55	55	M10	96	50	35	7,0	0,10	0,11
XVR 30-2	RE011979	RE012000	08-B	XOV 30-2	RE013004	RE013025	30	14,0	20,5	10	13,9	55	60	M10	96	50	35	7,0	0,11	0,12
XVR 30-3	RE011981	RE012001	10-B	XOV 30-3	RE013006	RE013026	30	16,5	25,0	12	16,6	55	70	M10	126	65	45	9,0	0,12	0,14
XVR 30-4	RE011983	RE012003	12-B	XOV 30-4	RE013008	RE013028	30	17,5	30,0	12	19,5	60	70	M10	148	74	45	11,0	0,16	0,15
XVR 40-4	RE011984	RE012004	12-B	XOV 40-4	RE013009	RE013029	40	17,5	30,0	12	19,5	80	80	M12	148	74	45	11,0	0,20	0,22
XVR 40-5	RE011986	RE012006	16-B				40	18,0	47,0	20		80	90	M12		55	16,0	0,22	0,31	



Polyethylene sliding block – Type: **XOV / Pattino in polietilene – Tipo: XOY**

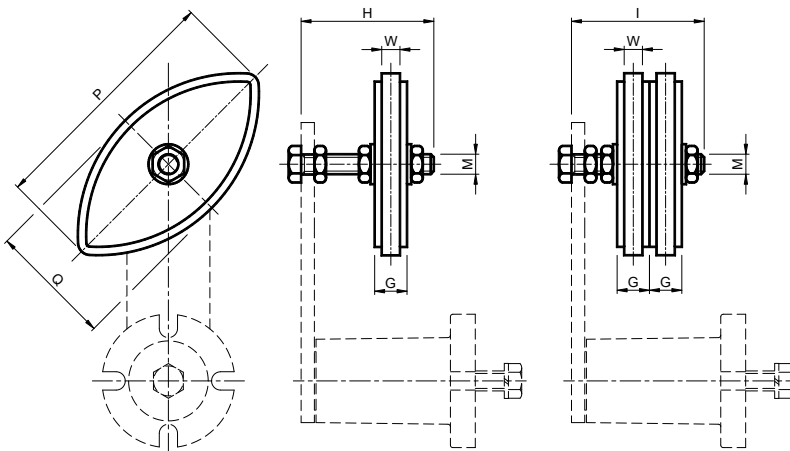

S.

D.

UK MATERIALS High molecular density polyethylene. Bolts and nuts are made of stainless steel.
USE Semi-circular sliding block suitable for middle-size and large distance between centres. Operating speed ≤ 20 m/min. Operating temperature $\leq 70^\circ\text{C}$.

IT MATERIALI Polietilene ad alta densità molecolare. Bulloneria in acciaio inossidabile.
IMPIEGO Profilo semicircolare adatto per medi e grandi interassi. Velocità di lavoro ≤ 20 m/min. Temperatura di lavoro $\leq 70^\circ\text{C}$.

Polyethylene wheel set – Type: XRO / Rotella in polietilene – Tipo: XRO

UK MATERIALS High molecular density polyethylene. Bush is made of galvanized steel. Bolts and nuts are made of stainless steel.
USE Idle wheel on the bush.
 Operating speed ≤ 30 m/min.
 Sliding block operating temperature $\leq 70^{\circ}\text{C}$.

IT MATERIALI Polietilene ad alta densità molecolare. Bussola in acciaio zincato e bulloneria in acciaio inossidabile.
IMPIEGO Rotella folle sulla bussola.
 Velocità di lavoro ≤ 30 m/min.
 Temperatura di lavoro $\leq 70^{\circ}\text{C}$.

Type Tipo	S Cod. N°	D Cod. N°	Chain Catena	Size Taglia	A	B	C	ØD	H	I	M	W	Weight Peso in [kg]	
													S.	D.
XRO 10-0	RE012095	RE012115	05-B	10	18	18		70	45	45	M8	2,5	0,14	0,15
XRO 10-1	RE012096	RE012116	06-B	10	18	18		70	45	50	M8	5,0	0,14	0,15
XRO 20-2	RE012099	RE012119	08-B	20	18	36		70	55	60	M10	7,0	0,15	0,20
XRO 30-2	RE012099	RE012120	08-B	30	18	36	36	70	55	60	M10	7,0	0,16	0,22
XRO 30-3	RE012101	RE012121	10-B	30	18	36		90	55	70	M10	9,0	0,19	0,28
XRO 30-4	RE012103	RE012123	12-B	30	18	36		90	55	70	M10	11,0	0,19	0,29
XRO 40-4	RE012104	RE012124	12-B	40	18	36	49	90	80	80	M12	11,0	0,25	0,35
XRO 40-5	RE012106	RE012126	16-B	40	18	49	82	110	80	90	M12	16,0	0,32	0,56

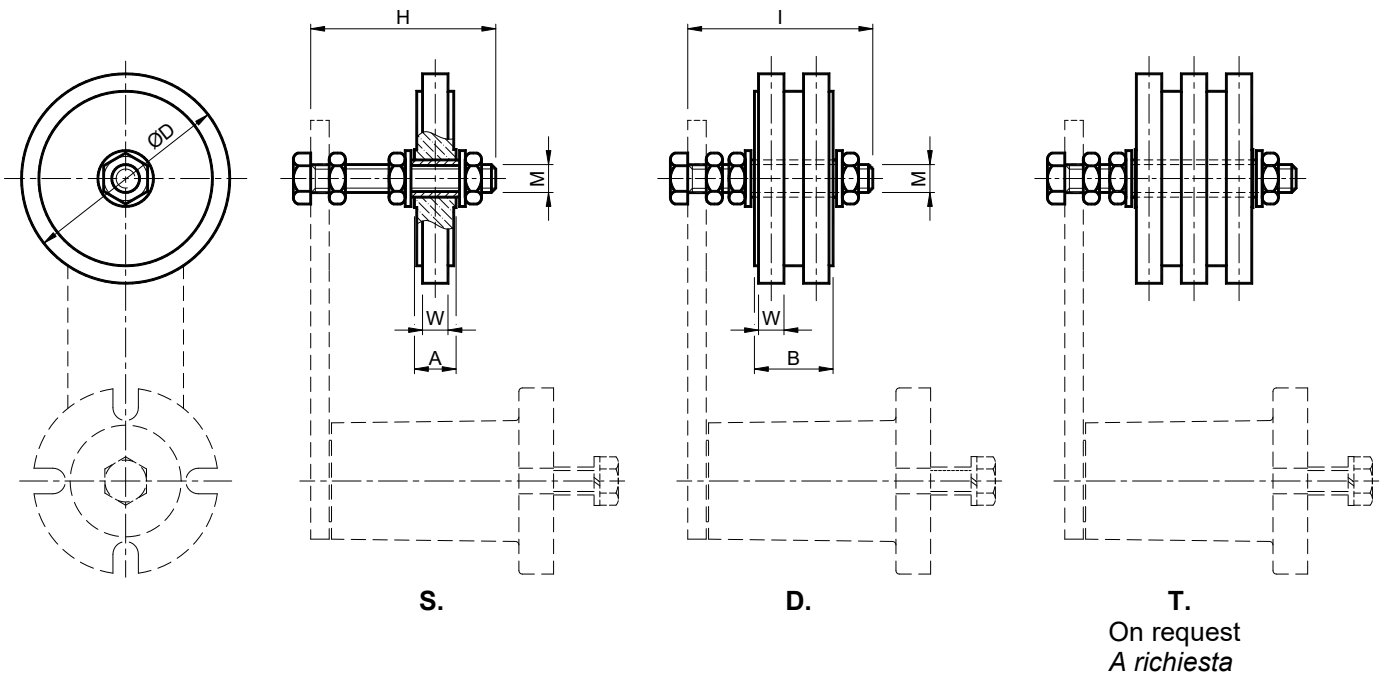

APPLICATION EXAMPLES / ESEMPI DI APPLICAZIONE



Idler Sprocket wheelset– Type: **XZN, AZN** / Pignone tendicatena– Tipo: **XZN, AZN**



UK MATERIALS The crown is made of plastic on a steel enlarged bearing.
TREATMENTS XZN type bolts and nuts are made of stainless steel. AZN type bolts and nuts are made of galvanized steel.
USE Operating speed ≤ 60 m/min.
 Operating temperature $\leq 100^{\circ}\text{C}$.

IT MATERIALI La corona è in materiale plastico stampata sul cuscinetto a base maggiorata in acciaio
TRATTAMENTI Per il tipo XZN bulloneria in acciaio inossidabile; per il tipo AZN bulloneria in acciaio zincato.
IMPIEGO Velocità di lavoro ≤ 60 m/min.
 Temperatura di lavoro $\leq 100^{\circ}\text{C}$.

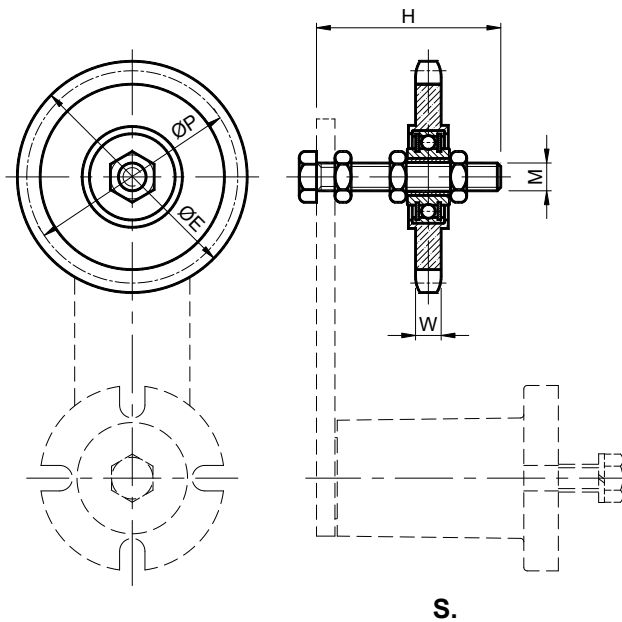
Inox Steel bolts Bulloneria Acciaio Inox			Zinc-plated Steel bolts Bulloneria Acciaio Zincato		Size Taglia		ØE	H	M	ØP	W	Z	Weight Peso in [kg]
Type Tipo	S Cod. N°	Chain Catena	Type Tipo	S Cod. N°									
XZN 20-1S	RE012155	06-B1	AZN 20-1S	RE012440	20	68,0	55	M10	63,90	5,3	21	0,28	
XZN 30-1S	RE012155	06-B1	AZN 30-1S	RE012440	30	68,0	55	M10	63,90	5,3	21	0,28	
XZN 30-2S	RE012158	08-B1	AZN 30-2S	RE012443	30	77,8	55	M10	73,14	7,2	18	0,30	
XZN 30-3S	RE012159	10-B1	AZN 30-3S	RE012444	30	93,0	60	M10	86,39	9,1	17	0,33	
XZN 40-3S	RE012160	10-B1	AZN 40-3S	RE012445	40	93,0	80	M12	86,39	9,1	17	0,35	



APPLICATION EXAMPLES / ESEMPI DI APPLICAZIONE





Idler Sprocket wheelset – Type: XZK / Pignone tendicatena con cuscinetto – Tipo: XZK



MATERIALS The crown, bolts and nuts are made of stainless steel, 2RS stainless steel bearing.
USE Steel crown on standard stainless steel bearing.
 Operating speed ≤ 60 m/min.
 Operating temperature ≤ 100°C.

MATERIALI Corona e bulloneria in acciaio inossidabile, cuscinetto 2RS in acciaio inox.
IMPIEGO Il pignone è costituito da una corona in acciaio, montata su cuscinetti unificati inox.
 Velocità di lavoro ≤ 60 m/min.
 Temperatura di lavoro ≤ 100°C.

Type Tipo	S Cod. N°	D Cod. N°	T Cod. N°	Chain Catena	Size Taglia	A	ØE	H	I	L	M	ØP	W	Z	Weight Peso in [kg]		
															S.	D.	T.
XZK 20-1	RE012310	RE012340		06-B	20	9	49,3	55	55		M10	45,81	5,3	15	0,13	0,23	
XZK 30-1	RE012310	RE012341	RE012370	06-B	30	9	49,3	55	60	70	M10	45,81	5,3	15	0,13	0,23	0,26
XZK 30-2	RE012314	RE012344		08-B	30	9	65,5	55	60		M10	61,09	7,2	15	0,21	0,37	
XZK 40-2			RE012374	08-B	40	12	65,5			80	M12	61,09	7,2	15			0,51
XZK 40-3	RE012318	RE012348	RE012377	10-B	40	12	83,0	80	80	80	M12	76,36	9,1	15	0,38	0,60	0,96
XZK 40-4	RE012321	RE012351	RE012381	12-B	40	12	99,8	80	80	90	M12	91,63	11,1	15	0,56	1,00	1,50
XZK 40-5	RE012325	RE012355		16-B	40	12	117,0	100	120		M12	106,12	16,2	13	1,00	1,90	

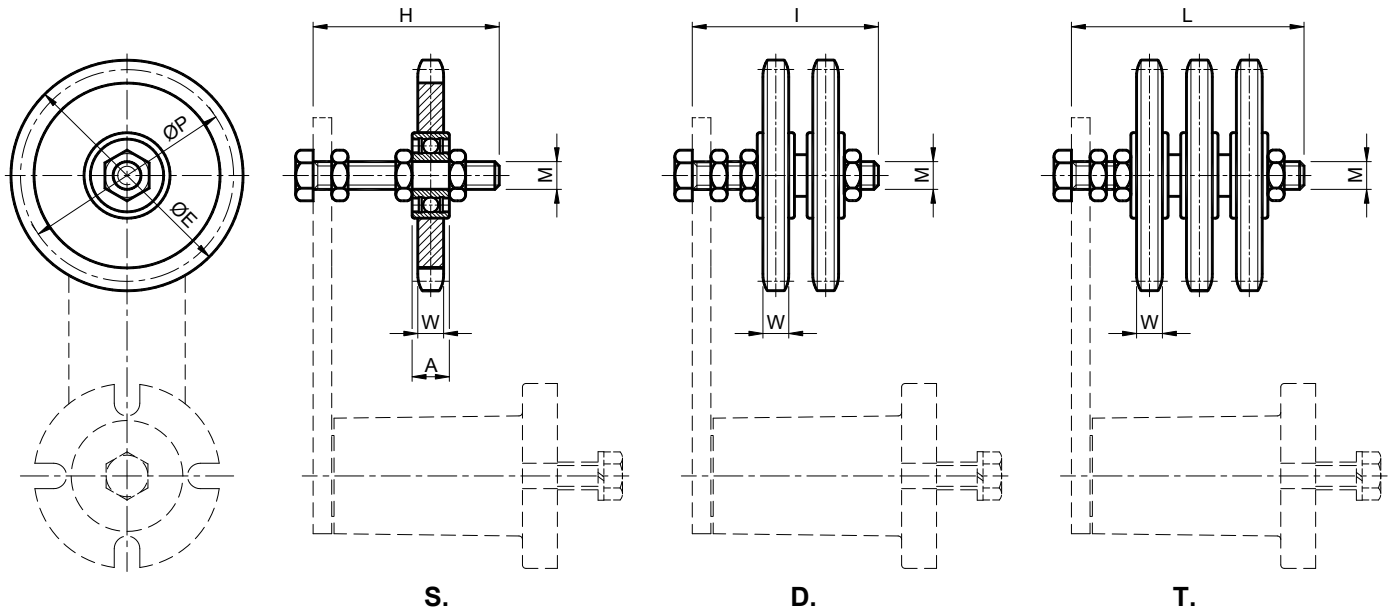

APPLICATION EXAMPLES / ESEMPI DI APPLICAZIONE



Polyamide roller – Type: **XRP**

⊙ For polyamide-roller / Screw “M”

Rullo in poliammide – Tipo: XRP

⊙ *Per rullo in poliammide / Vite “M”*



Stainless steel roller – Type: **XRU**

* For stainless steel-roller / Screw “P”

Rullo in acciaio inox – Tipo: XRU

* *Per rullo in acciaio inox / Vite “P”*



MATERIALS Roller and stoppers are made of black polyamide, steel bearings, spacers and screws are made of stainless steel.

USE Operating temperature $\leq 70^{\circ}\text{C}$.

MATERIALI Rullo e tappi in poliammide nero, cuscinetti in acciaio, distanziali e viti in acciaio inox.

IMPIEGO Temperatura di lavoro del rullo $\leq 70^{\circ}\text{C}$.

MATERIALS Roller, spacers and screws are made of stainless steel, steel bearings, stoppers are made of black polyamide.

USE Operating temperature $\leq 70^{\circ}\text{C}$.

MATERIALI Rullo, distanziali e viti in acciaio inox, cuscinetti in acciaio, tappi in poliammide nero.

IMPIEGO Temperatura di lavoro del rullo $\leq 70^{\circ}\text{C}$.



Type Tipo	Cod. N°	Weight Peso in [kg]	A	B	C	ØD	E	*F	⊙G	⊙M	*P	Max. speed Velocità max. [rpm]	Size Taglia	Type Tipo	Cod. N°	Weight Peso in [kg]
XRP 1	RE011960	0,08	38	35	3	30	13	2	2	M8	M8	8000	10	XRU 1	RE010970	0,16
XRP 2/3	RE011962	0,18	51	45	6	40	16	2	2	M10	M10	8000	20-30	XRU 2/3	RE010972	0,37
XRP 4	RE011964	0,40	68	60	8	60	21	4	2	M12	M16	6000	40	XRU 4	RE010974	0,85

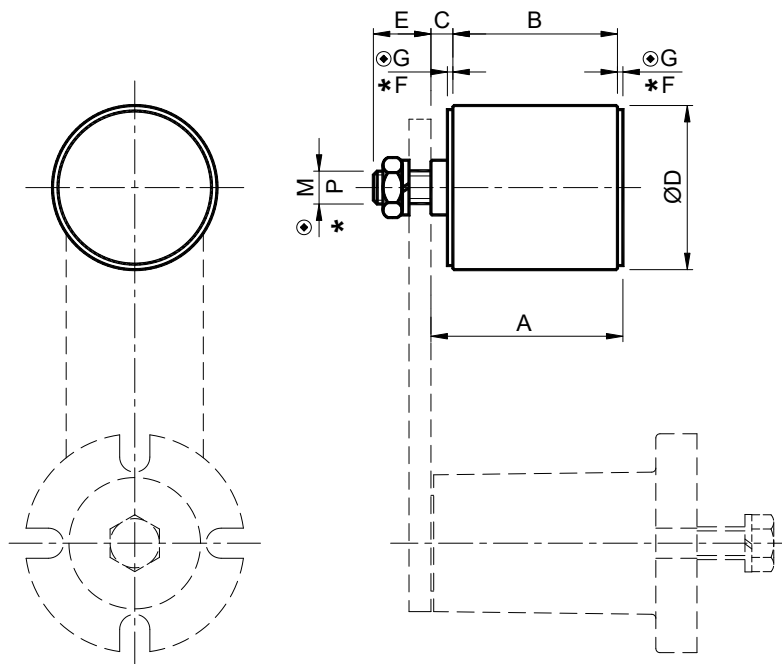



Preloading – Type: XPR in stainless steel / Pre carica – Tipo: XPR in acciaio inox

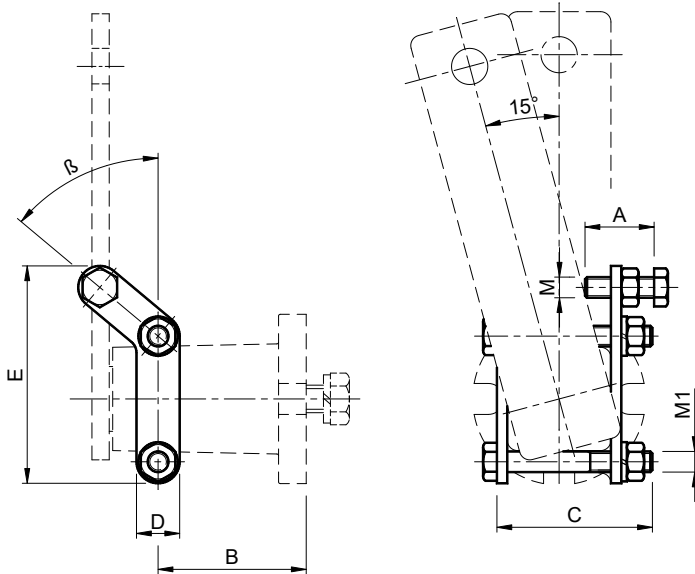

UK MATERIALS Plates, bolts and nuts are made of stainless steel.
USE It allows to preload easily the elastic element, to predetermine the initial load and the work range. This product is suitable for the realization of pressure sets, calibrators and precision shock absorbers.

IT MATERIALI Piastrine e bulloneria in acciaio inossidabile.

IMPIEGO Consente di precaricare facilmente l'elemento elastico, predeterminare il carico iniziale ed il campo di lavoro. Questo prodotto è ideale per la realizzazione di gruppi di pressione, calibratori ed ammortizzatori di precisione.

Type Tipo	Cod.N°	β	A	B	C	D	E	M	M1	Weight Peso in [kg]
XPR 10	RE012450	47,5°	20	34,5	40	12,5	55,8	M 6	M6	0,065
XPR 20	RE012452	50,0°	20	44,0	45	12,5	63,1	M 6	M6	0,070
XPR 30	RE012454	45,0°	25	54,2	55	17,0	81,3	M 8	M8	0,160
XPR 40	RE012456	44,5°	30	75,7	80	16,0	96,5	M10	M8	0,390

Elastic elements – Type: SN 5 (RE010880) / Elementi elastici – Tipo: SN 5 (RE010880)

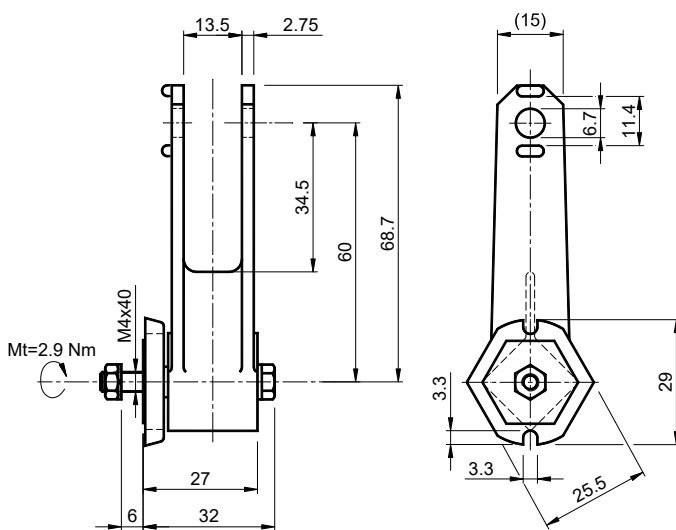

UK MATERIALS It is made of plastic material. Bolts and nuts are made of steel.

TREATMENTS Bolts and nuts are made of galvanized steel (on demand, it can be provided with stainless steel bolts and screws).

USE Mini tensioners or small pressure units.

IT MATERIALI Realizzato in materiale plastico. Bulloneria e riscontro in acciaio.

TRATTAMENTI Bulloneria e riscontro in acciaio zincato. (A richiesta puo' essere fornito con bulloneria in acciaio inox).

IMPIEGO Piccoli tensionamenti o gruppi di pressione.

Mt: Fixing torque screw / Coppia di serraggio vite