

**KIT per tendicinghia / KIT for belt-tensioners**

Rullo in acciaio su forcella – Tipo: **2RAU** / Rullo in poliammide su forcella – Tipo: **2RAP**  
 Roller set in steel – Type: **2RAU** / Roller set in polyamide – Type: **2RAP**



**2RAU**



**2RAP**

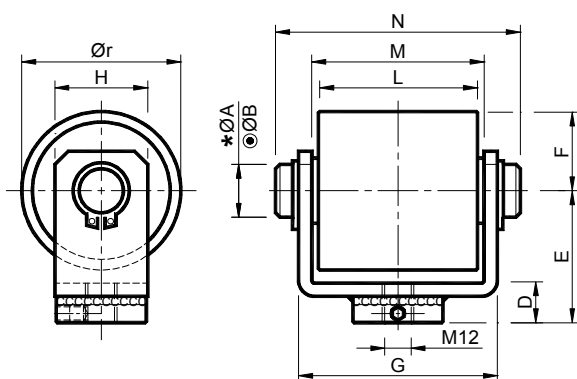

**MATERIALI 2RAU:** Forcella, cuscinetti, perno, distanziali e rullo in acciaio.

**2RAP:** Forcella, cuscinetti, perno e distanziali in acciaio, rullo in poliammide PA6+MoS nero.

**TRATTAMENTI 2RAU:** Forcella verniciata a forno, particolari metallici in acciaio zincato.

**2RAP:** Forcella verniciata a forno, particolari metallici in acciaio zincato, rullo tornito 1.6.

**IMPIEGO** Rullo con cuscinetti ZZ lubrificati.

**MATERIALS 2RAU:** Fork, bearings, pin, spacers, roller made of steel.

**2RAP:** Fork, bearings, pin, spacers made of steel, roller made of black polyamide PA6+MoS.

**TREATMENTS 2RAU:** Fork oven painted, metallic components made of galvanized steel

**2RAP:** Fork oven painted, metallic components made of galvanized steel, The roller is turned 1.6.

**USE** Roller with ZZ greased bearings.

\* ØA : Per rullo in acciaio / For roller made of steel

○ ØB : Per rullo in poliammide / For roller made of polyamide

Rullo in acciaio Roller set in steel													Rullo in poliammide Roller set in polyamide			
Tipo Type	Cod. N°	* ØA	○ ØB	D	E	F	G	H	L	M	N	Ør	Tipo Type	Cod. N°	Peso Weight in kg	
															2RAU	2RAP
2RAU 4	TB002052	16	12	15	50	30	75	35	60	65	85	60	2RAP 4	TB002062	1.16	0.65
2RAU 5	TB002053	20	20	20	65	40	111	45	90	95	121.5	80	2RAP 5	TB002063	2.98	1.70
2RAU 6	TB002054	20	20	20	70	45	156	45	135	140	167	90	2RAP 6	TB002064	5.80	2.49

Campo di lavoro Working field				Campo di lavoro Working field			
Tipo Type	Ø Rullo Roller	Numero di giri max Max rpm	Cuscinetto Bearing	Tipo Type	Ø Rullo Roller	Numero di giri max Max rpm	Cuscinetto Bearing
2RAU 4	60	9500	6304	2RAP 4	60	6000	6301
2RAU 5	80	6500	6306	2RAP 5	80	5000	6304
2RAU 6	90	6500	6306	2RAP 6	90	4500	6304

Il numero di giri descritto in tabella è indicativo. L'applicazione va valutata in base al tipo d'impiego, il fattore di servizio e le condizioni di lavoro.  
 The rpm indicated in the chart is approximate. The application must be considered according to the type of use, the service factor and the working conditions.