

TC2   **ARIA**  **OLIO**
BREVETTATO - PATENDEO

C 2013

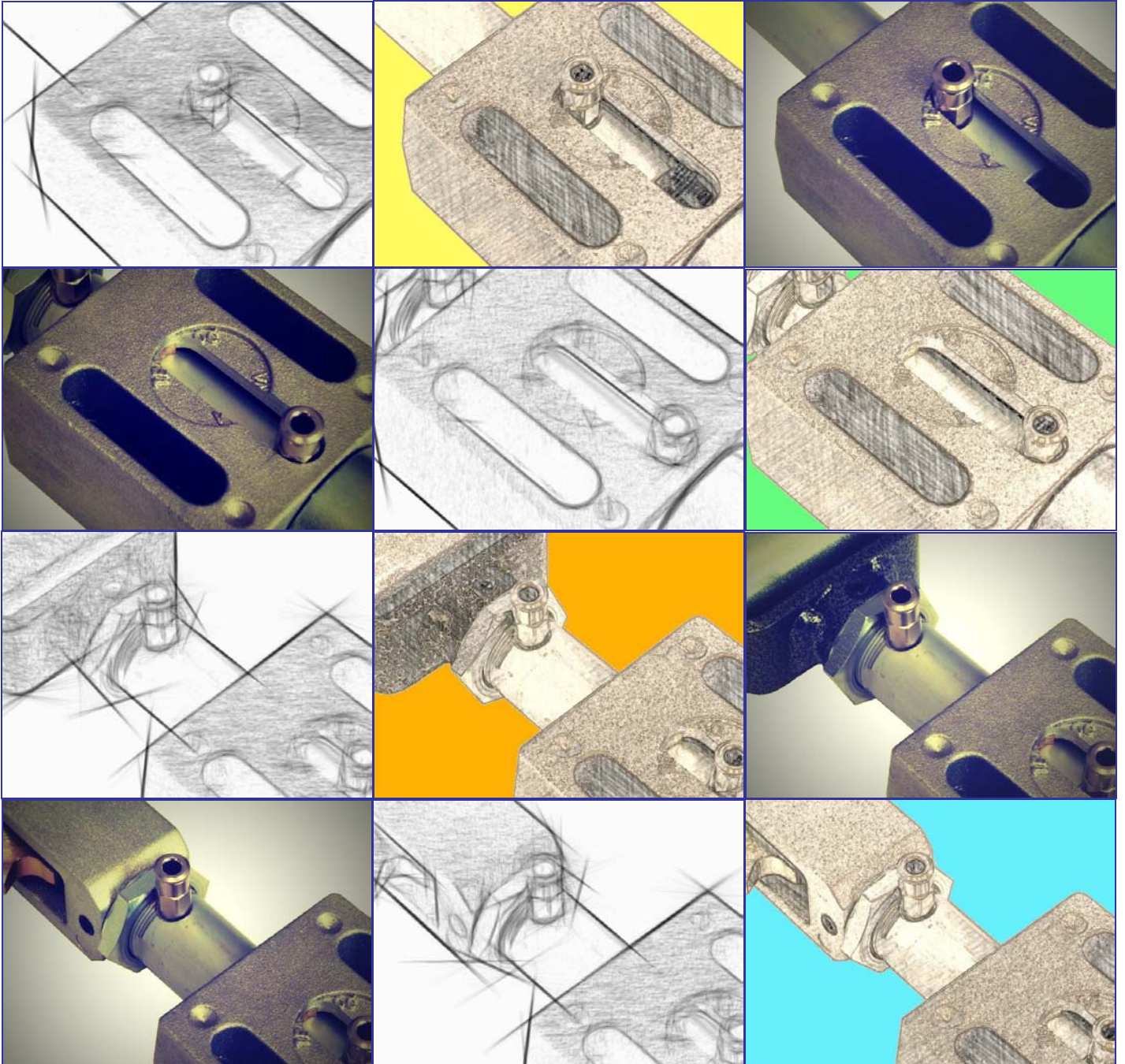

TECNIDEA CIDUE
S.r.l.



ARIA – OLIO Brevettato

ELEMENTO ELASTICO ASSIALE PNEUMATICO O IDRAULICO – TENDICATENA AUTOMATICO – TENDICINGHIA AUTOMATICO AMMORTIZZATORE – GRUPPO DI PRESSIONE – GRUPPO DI BLOCCAGGIO

Principali caratteristiche: ARIA: Cilindro Pneumatico, OLIO: Cilindro Idraulico, Funzionamento in spinta oppure in tiro, Forza di spinta variabile oppure costante, Controllo della forza sviluppata, Finecorsa per controllo, Con OLIO elevatissime forze sviluppate, Semplicità di montaggio.

Gli articoli ARIA ed OLIO sono caratterizzati da proposte innovative che migliorano gli elementi elastici nel funzionamento, nell'applicazione e permettono nuovi impieghi che arricchiscono le soluzioni tecniche e le realizzazioni meccaniche.

Innovazioni tecniche comuni: – semplicità nel montaggio in quanto privi di forze assiali da caricare – spinta sviluppata costante – possibilità di variare la forza esercitata – variazione della corsa manualmente ed automaticamente – possibilità di lavorare in spinta oppure in tiro – bloccaggio dell'elemento elastico in una qualsiasi posizione della corsa (bilanciando le alimentazioni) – regolazione delle funzioni manualmente o automaticamente, anche a distanza – regolazione ed autoregolazione degli articoli ARIA-OLIO a mezzo sistemi elettrici-elettronici-pneumatici o idraulici con possibilità di ricevere oppure dare comandi – dotazione di fine corsa elettrici per la segnalazione della posizione di lavoro o di fine corsa – deceleratore pneumatico-idraulico-meccanico (a molle) o sistemi misti fra loro – con eliminazione della spinta a fine corsa e possibilità di ripristino della stessa all'inizio del ciclo.

Elemento elastico assiale ARIA:

L'utilizzo di questo articolo migliora notevolmente le applicazioni degli elementi elastici assiali per la sua eccezionale capacità di adattarsi alle varie situazioni di lavoro. La soluzione che più lo caratterizza è l'utilizzo dell'aria compressa come elemento elastico deformabile anziché i vecchi imprecisi sistemi meccanici ora superati.

Elemento elastico assiale OLIO:

OLIO è un articolo che può essere impiegato sia nelle normali applicazioni ARIA, come in altre molto più gravose, in quanto ne amplifica le caratteristiche meccaniche. Ciò che più lo evidenzia tecnicamente è l'utilizzo di un fluido incompressibile (l'olio) come unità di spinta che gli consente di sviluppare forze elevatissime e se necessario unidirezionali.

L'impiego di questi articoli come tendicatena o tendicinghia, conserva i vantaggi presenti nella serie Ten Bloc, in particolar modo: - Intercambiabilità delle teste V-L-R-RR e C; - Possibilità di rotazione della testa di 360° per la ricerca della migliore posizione di lavoro e per un autoallineamento con l'organo da tensionare; - Eventuale dotazione di un fine corsa elettrico per il controllo del corretto funzionamento dell'elemento elastico e della macchina su cui è installato.

ARIA – OLIO Patented

PNEUMATIC OR HYDRAULIC AXIAL ELASTIC ELEMENT – AUTOMATIC CHAIN TENSIONER – AUTOMATIC BELT TENSIONER SHOCK ABSORBER – PRESSURE UNIT – LOCKING UNIT

Main features: ARIA: *pneumatic cylinder*, OLIO: *hydraulic cylinder*, operation by thrust or traction, variable or constant thrust force, control of developed force, control limit stop, with OLIO extremely high developed force, easy to assemble.

The ARIA and OLIO items are characterised by innovative ideas that improve the functioning and application of elastic elements and enable new uses that enrich the available technical solutions and mechanical functions.

Common technical innovation: – easy to assemble as there is no axial force to load – constant developed thrust – option of adjusting effective strength – manual and automatic stroke variation – option of working by thrust or traction – locking the elastic part at any position during the stroke (balancing the feeds) – manual or automatic function adjustment, also remote – adjustment and auto-adjustment of ARIA-OLIO items through electrical-electronic-pneumatic or hydraulic systems with option to receive or give commands – fitted with electrical limit stops to show position of work or end of stroke – pneumatic-hydraulic-mechanical (with springs) deceleration or mixed systems – with elimination of thrust at end of stroke and option to reactivate it at the beginning of the cycle.

ARIA axial elastic element:

The use of this item significantly improves applications of axial elastic elements thanks to its excellent ability to adapt to different work situations. Its most characteristic solution is the use of compressed air as a deformable elastic element instead of the old inaccurate mechanical systems which are now obsolete.

OLIO axial elastic element:

OLIO is an item that can be used both in normal ARIA applications and other more onerous ones as it enhances their mechanical characteristics. Its most characteristic technical feature is the use of incompressible fluid (oil) as the thrust unit, making it possible to develop extremely high levels of force, which may be one-directional if necessary.

The use of these items as chain or belt tensioners maintains the advantages of the Ten Bloc series, especially: - option to interchange heads V-L-R-RR and C; - possibility to rotate head 360° to find best working position and for self-alignment with item to be tensioned; - option to fit with travel-end switch to check proper functioning of elastic element and the machine it is installed on.



ARIA OLIO – ARIA OLIO



AS pag.109



AD pag.109



AS 5 pag.110



AD 5 pag.110



OS pag.111



OD pag.111



OS 5 / OS 25 pag.112-113



OD 5 / OD 25 pag.112-113



VA pag.115



LA pag.115



FRA pag.116



FA pag.116



RRA pag.117



RAUA pag.118



RAPA pag.118



E pag.114

Elementi elastici **ARIA** – Tipo: **AS 2** (semplice effetto in spinta)
ARIA Elastic elements – Type: AS 2 (simple action in thrust condition)

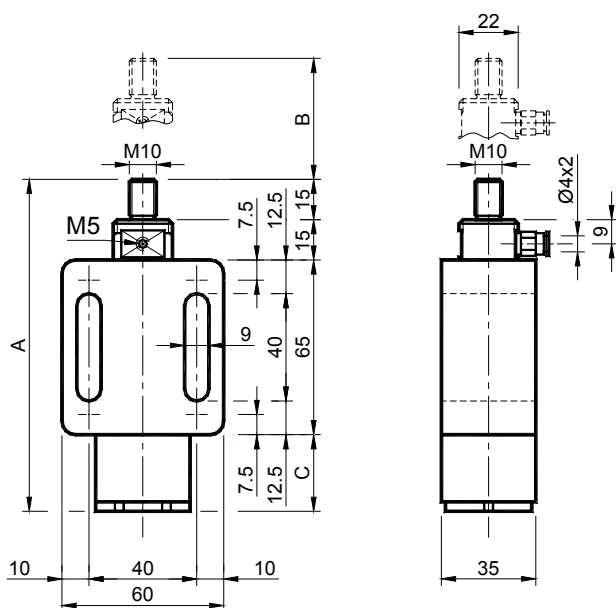

MATERIALI Corpo in alluminio, cilindro in alluminio, tappi in acciaio.

TRATTAMENTI Alluminio sabbiato, particolari metallici zincati.

IMPIEGO Questo articolo utilizza una molla ad aria come elemento di spinta, quindi è indicato per spingere o pressare ma anche per ammortizzare od assorbire vibrazioni, oscillazioni, urti, strappi, etc.

Funzionamento: A SEMPLICE EFFETTO (IN SPINTA).

MATERIALS Body, cylinder made of aluminium, stoppers made of steel.

TREATMENTS Sandblasted aluminium, galvanized metallic components.

USE This element is equipped with an air spring acting as a thrust element, so it is suitable to thrust or to press, but also to amortize or absorb vibrations, oscillations, shocks, tearings, etc.

Functioning: SINGLE ACTION (IN THRUST CONDITIONS).



Tipo Type	Cod. N°	A	B	C	Newton (0÷6 bar)		Peso Weight in kg	Tipo Type	Cod. N°
					Spinta Push	Tiro Pull			
AS 2-10	OL010010	148	30	53	0÷150	0÷105	0.61	AD 2-10	OL010537
AS 2-11	OL010011	163	45	68	0÷150	0÷105	0.77	AD 2-11	OL010538
AS 2-12	OL010012	213	95	118	0÷150	0÷105	1.15	AD 2-12	OL010539
AS 2-13	OL010013	263	145	168	0÷150	0÷105	1.60	AD 2-13	OL010540
AS 2-14	OL010014	313	195	218	0÷150	0÷105	1.80	AD 2-14	OL010541

Elementi elastici **ARIA** – Tipo: **AD2** (doppio effetto in spinta e in tiro)
ARIA Elastic elements – Type: AD2 (double action in thrust and drag condition)

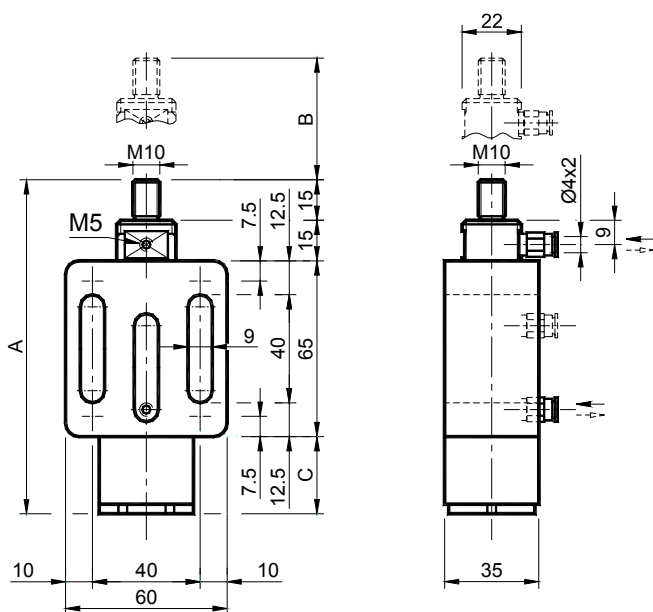

MATERIALI Corpo in alluminio, cilindro in alluminio, tappi in acciaio.

TRATTAMENTI Alluminio sabbiato, particolari metallici zincati.

IMPIEGO Questo articolo utilizza una molla ad aria come elemento di spinta, quindi è particolarmente indicato in tutte quelle applicazioni si renda necessario assorbire vibrazioni, oscillazioni, urti, strappi, etc.

Funzionamento: A DOPPIO EFFETTO (IN SPINTA E INTIRO).

MATERIALS Body, cylinder made of aluminium, stoppers made of steel.

TREATMENTS Sandblasted aluminium, galvanized metallic components.

USE This element is equipped with an air spring acting as a thrust element, so it is particularly suitable for all the cases which require absorption of vibrations, oscillations, shocks, tearings, etc.

Functioning: DOUBLE ACTION (IN THRUST AND DRAG CONDITIONS).



Elementi elastici ARIA – Tipo: AS5 (semplice effetto in spinta)
ARIA Elastic elements – Type: AS5 (single action in thrust condition)

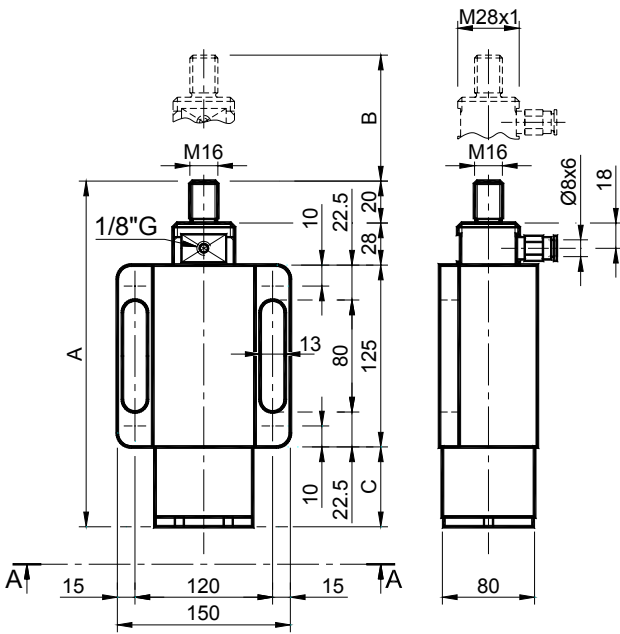

MATERIALI Corpo in alluminio, cilindro in alluminio, tappi in acciaio.
TRATTAMENTI Alluminio sabbiato, particolari metallici zincati.
IMPIEGO Questo articolo utilizza una molla ad aria come elemento di spinta, quindi è indicato per spingere o pressare ma anche ammortizzare od assorbire vibrazioni, oscillazioni, urti, strappi, etc.
 Funzionamento: A SEMPLICE EFFETTO (IN SPINTA).

MATERIALS Body, cylinder made of aluminium, stoppers made of steel.
TREATMENTS Sandblasted aluminium, galvanized metallic components.
USE This element is equipped with an air spring acting as a thrust element, so it's particularly suitable to thrust or to press, but also to amortize or absorb vibrations, oscillations, shocks, tearings, etc.
 Functioning: SINGLE ACTION (IN THRUST CONDITIONS).

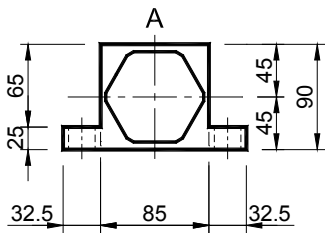

Vista A-A

Tipo Type	Cod. N°	A	B	C	Newton (0÷6 bar)		Peso Weight in kg	Tipo Type	Cod. N°
					Spinta Push	Tiro Pull			
AS 5-10	OL010015	243	50	70	0÷830	0÷710	6.35	AD 5-10	OL010542
AS 5-11	OL010016	293	100	120	0÷830	0÷710	6.85	AD 5-11	OL010543
AS 5-12	OL010017	343	150	170	0÷830	0÷710	7.35	AD 5-12	OL010544
AS 5-13	OL010018	393	200	220	0÷830	0÷710	7.95	AD 5-13	OL010545
AS 5-14	OL010019	443	250	270	0÷830	0÷710	8.90	AD 5-14	OL010546

Elementi elastici ARIA – Tipo: AD5 (doppio effetto in spinta e in tiro)
ARIA Elastic elements – Type: AD5 (double action in thrust and drag condition)

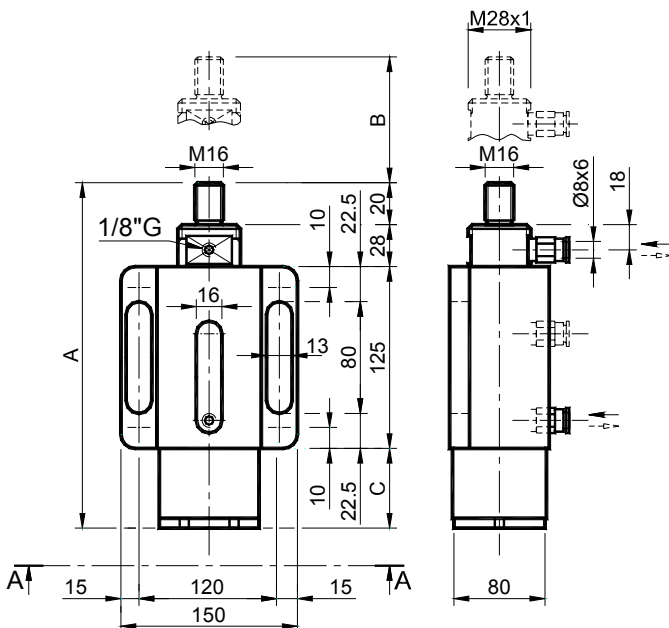

MATERIALI Corpo in alluminio, cilindro in alluminio, tappi in acciaio.
TRATTAMENTI Alluminio sabbiato, particolari metallici zincati.
IMPIEGO Questo articolo utilizza una molla ad aria come elemento di spinta, quindi è indicato per spingere o pressare ma anche ammortizzare od assorbire vibrazioni, oscillazioni, urti, strappi, etc.
 Funzionamento: A DOPPIO EFFETTO (IN SPINTA E IN TIRO).

MATERIALS Body, cylinder made of aluminium, stoppers made of steel.
TREATMENTS Sandblasted aluminium, galvanized metallic components.
USE This element is equipped with an air spring acting as a thrust element, so it's particularly suitable for all the cases which require absorption of vibrations, oscillations, shocks, tearings, etc.
 Functioning: DOUBLE ACTION (IN THRUST AND DRAG CONDITIONS).

Elementi incompressibili **OLIO** – Tipo: **OS2** (semplice effetto in spinta)
OLIO Incompressible Elements – Type: OS2 (simple action in thrust condition)

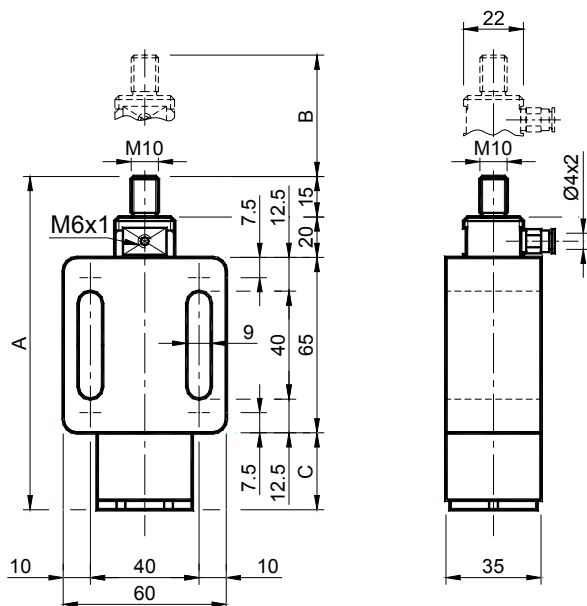

MATERIALI Corpo in alluminio, cilindro in alluminio, tappi in acciaio.

TRATTAMENTI Alluminio sabbiato, particolari metallici zincati.

IMPIEGO Questo articolo sviluppa la forza assiale per mezzo dell'olio alimentato in pressione. Con le applicazioni oleodinamiche si ottengono gruppi incompressibili che esprimono forze unidirezionali.

Funzionamento: A SEMPLICE EFFETTO (IN SPINTA).

PRESSIONE DI ESERCIZIO: max 40 BAR.

MATERIALS Body and cylinder made of aluminium, stoppers made of steel.

TREATMENTS Sandblasted aluminium, galvanized metallic components.

USE This item develops its axial force by means of the pressured oil.

Incompressible units with their unidirectional force can be obtained through oleodynamical applications.

Functioning: SINGLE ACTION (IN DRAG CONDITIONS).

OPERATING PRESSURE: max 40 BAR.



Tipo Type	Cod. N°	A	B	C	Newton (0÷40 bar)		Peso Weight in kg	Tipo Type	Cod. N°
					Spinta Push	Tiro Pull			
OS 2-10	OL020010	153	30	53	0÷800	0÷490	0.61	OD 2-10	OL020550
OS 2-11	OL020011	168	45	68	0÷800	0÷490	0.77	OD 2-11	OL020551
OS 2-12	OL020012	218	95	118	0÷800	0÷490	1.15	OD 2-12	OL020552
OS 2-13	OL020013	268	145	168	0÷800	0÷490	1.60	OD 2-13	OL020553
OS 2-14	OL020014	318	195	218	0÷800	0÷490	1.80	OD 2-14	OL020554

Elementi incompressibili **OLIO** – Tipo: **OD2** (doppio effetto in spinta e in tiro)
OLIO Incompressible Elements – Type: OD2 (double action in thrust and drag conditions)

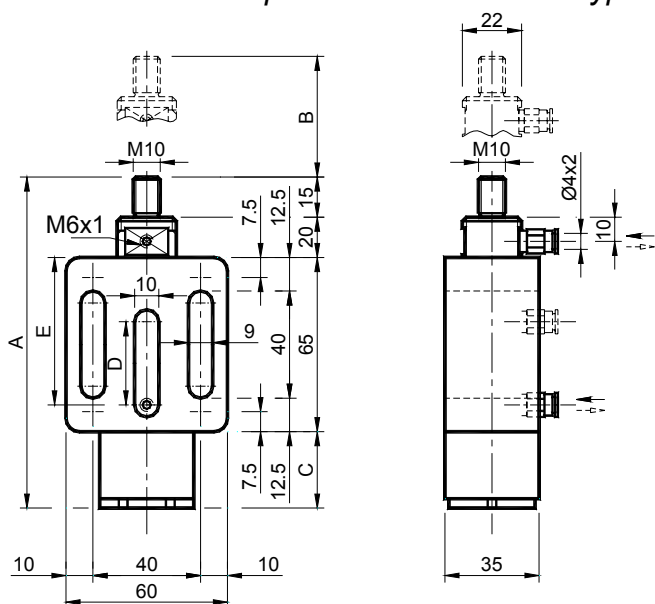

MATERIALI Corpo in alluminio, cilindro in alluminio, tappi in acciaio.

TRATTAMENTI Alluminio sabbiato, particolari metallici zincati.

IMPIEGO Questo articolo sviluppa la forza assiale per mezzo dell'olio alimentato in pressione. Con le applicazioni oleodinamiche si ottengono gruppi incompressibili che esprimono forze unidirezionali.

Funzionamento: A DOPPIO EFFETTO (IN SPINTA E IN TIRO).

PRESSIONE DI ESERCIZIO: max 40 BAR.

MATERIALS Body and cylinder made of aluminium, stoppers made of steel.

TREATMENTS Sandblasted aluminium, galvanized metallic components.

USE This item develops its axial force by means of the pressured oil.

Incompressible units with their unidirectional force can be obtained through oleodynamical applications.

Functioning: DOUBLE ACTION (IN THRUST AND DRAG CONDITIONS).

OPERATING PRESSURE: max 40 BAR.



Elementi incompressibili **OLIO** – Tipo: **OS5** (semplice effetto in spinta)
OLIO Incompressible Elements – Type: **OS5** (simple action in thrust condition)

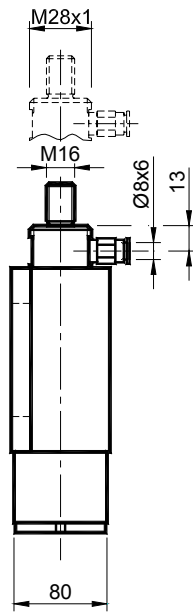
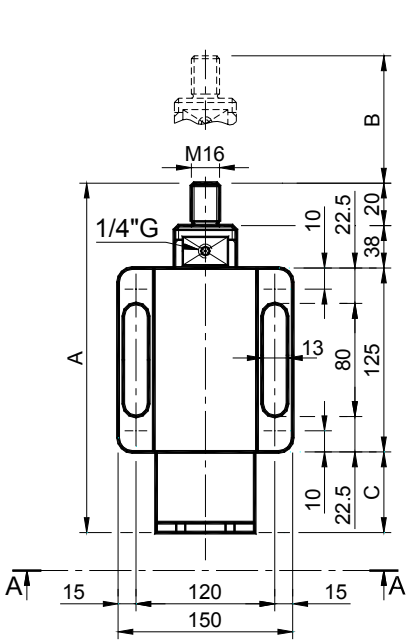

MATERIALI Corpo in alluminio, cilindro in alluminio, tappi in acciaio.
TRATTAMENTI Alluminio sabbiato, particolari metallici zincati.
IMPIEGO Questo articolo sviluppa la forza assiale per mezzo dell'olio alimentato in pressione. Con le applicazioni oleodinamiche si ottengono gruppi incompressibili che esprimono forze unidirezionali. Funzionamento: A SEMPLICE EFFETTO (IN SPINTA).
 PRESSIONE DI ESERCIZIO: max 40 BAR.

MATERIALS Body and cylinder made of aluminium, stoppers made of steel.
TREATMENTS Sandblasted aluminium, galvanized metallic components.
USE This item develops its axial force by means of the pressured oil. Incompressible units with their unidirectional force can be obtained through oleodynamical applications.
 Functioning: SINGLE ACTION (IN DRAG CONDITIONS).
 OPERATING PRESSURE: max 40 BAR.

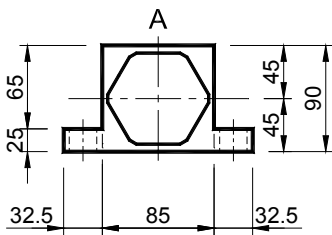

Tipo Type	Cod. N°	A	B	C	Newton (0÷40 bar)		Peso Weight in kg	Tipo Type	Cod. N°
					Spinta Push	Tiro Pull			
OS 5-10	OL020015	253	50	70	0÷5000	0÷4200	6.35	OD 5-10	OL020555
OS 5-11	OL020016	303	100	120	0÷5000	0÷4200	6.85	OD 5-11	OL020556
OS 5-12	OL020017	353	150	170	0÷5000	0÷4200	7.35	OD 5-12	OL020557
OS 5-13	OL020018	403	200	220	0÷5000	0÷4200	7.95	OD 5-13	OL020558
OS 5-14	OL020019	453	250	270	0÷5000	0÷4200	8.90	OD 5-14	OL020559

Elementi incompressibili **OLIO** – Tipo: **OD5** (doppio effetto in spinta e in tiro)
OLIO Incompressible Elements – Type: **OD5** (double action in thrust and drag condition)

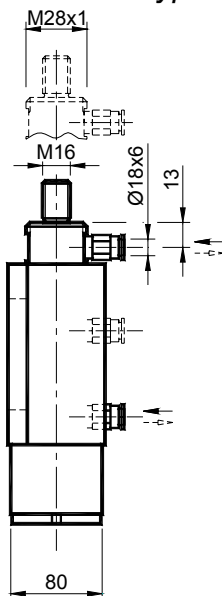
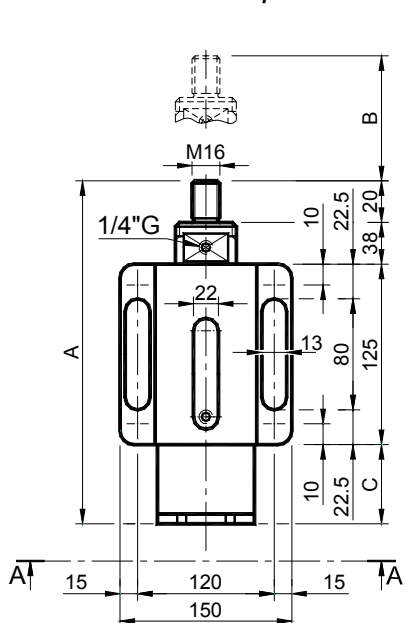

MATERIALI Corpo in alluminio, cilindro in alluminio, tappi in acciaio.
TRATTAMENTI Alluminio sabbiato, particolari metallici zincati.
IMPIEGO Questo articolo sviluppa la forza assiale per mezzo dell'olio alimentato in pressione. Con le applicazioni oleodinamiche si ottengono gruppi incompressibili che esprimono forze unidirezionali. Funzionamento: A DOPPIO EFFETTO (IN SPINTA E IN TIRO).
 PRESSIONE DI ESERCIZIO: max 40 BAR.

MATERIALS Body and cylinder made of aluminium, stoppers made of steel.
TREATMENTS Sandblasted aluminium, galvanized metallic components.
USE This item develops its axial force by means of the pressured oil. Incompressible units with their unidirectional force can be obtained through oleodynamical applications.
 Functioning: DOUBLE ACTION (IN THRUST AND DRAG CONDITIONS).
 OPERATING PRESSURE: max 40 BAR.

Elementi incompressibili **OLIO** – Tipo: **OS25-10** (semplice effetto in spinta)
OLIO Incompressible Elements – Type: OS25-10 (simple action in thrust condition)

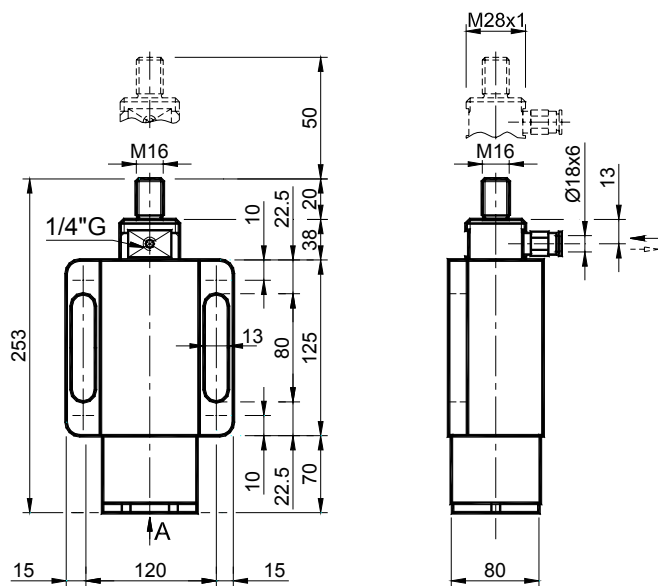

Cod. **OL020026**

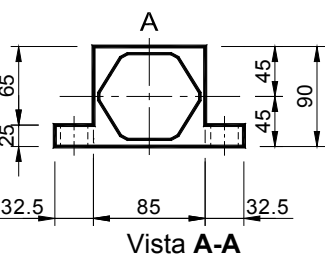

Vista A-A

MATERIALI Corpo in acciaio, cilindro in acciaio, tappi in acciaio.

TRATTAMENTI Particolari metallici zincati.

IMPIEGO Questo articolo sviluppa la forza assiale per mezzo dell'olio alimentato in pressione. Con le applicazioni oleodinamiche si ottengono gruppi incompressibili che esprimono forze unidirezionali.

Funzionamento: A SEMPLICE EFFETTO (IN SPINTA).

PRESSIONE DI ESERCIZIO: max 380 BAR.

FORZA DI SPINTA: 0÷30500 N.

MATERIALS Body made of steel, cylinder and stoppers made of steel.

TREATMENTS Galvanized metallic components.

USE This item develops its axial force by means of the pressured oil.

Incompressible units with their unidirectional force can be obtained through oleodynamical applications.

Functioning: SINGLE ACTION (IN THRUST CONDITION).

OPERATING PRESSURE: max 380 BAR.

THRUST FORCE: 0÷30500 N.

Peso / Weight: 10.60 kg



Elementi incompressibili **OLIO** – Tipo: **OD25-10** (doppio effetto in spinta e in tiro)
OLIO Incompressible Elements – Type: OD25-10 (double action in thrust and drag condition)

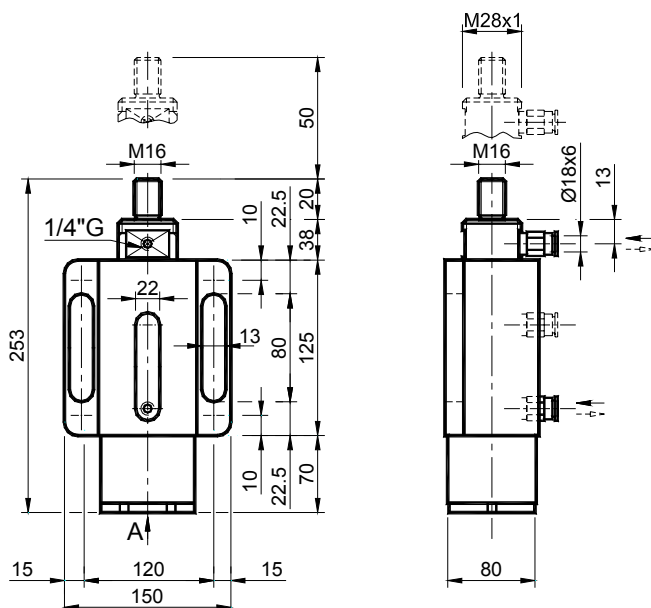

Cod. **OL020566**

MATERIALI Corpo in acciaio, cilindro in acciaio, tappi in acciaio.

TRATTAMENTI Particolari metallici zincati.

IMPIEGO Questo articolo sviluppa la forza assiale per mezzo dell'olio alimentato in pressione. Con le applicazioni oleodinamiche si ottengono gruppi incompressibili che esprimono forze unidirezionali.

Funzionamento: A DOPPIO EFFETTO (IN SPINTA E IN TIRO).

PRESSIONE DI ESERCIZIO: max 380 BAR.

FORZA DI SPINTA: 0÷30500 N.

FORZA DI TIRO: 0÷20900 N.

MATERIALS Body made of steel, cylinder and stoppers made of steel.

TREATMENTS Galvanized metallic components.

USE This item develops its axial force by means of the pressured oil.

Incompressible units with their unidirectional force can be obtained through oleodynamical applications.

Functioning: DOUBLE ACTION (IN THRUST AND DRAG CONDITIONS).

OPERATING PRESSURE: max 380 BAR.

THRUST FORCE: 0÷30500 N.

DRAG FORCE: 0÷20900 N.

Peso / Weight: 10.60 kg



FINECORSA ELETTRICO - Tipo: "E" / TRAVEL-END SWITCH Type: "E"

Cod. OL001590

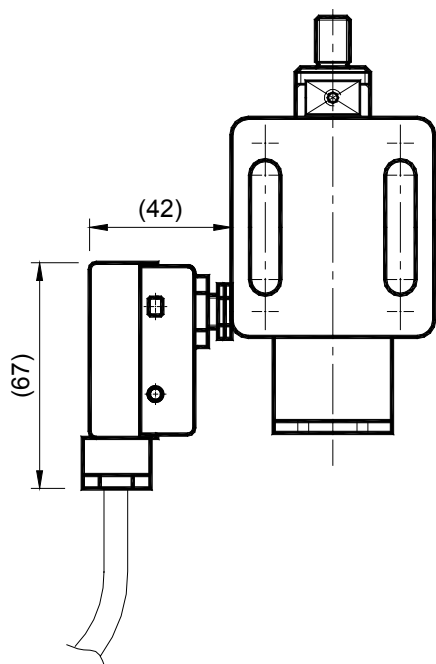

Gli elementi ARIA/OLIO, possono essere forniti a richiesta con finecorsa elettrico "E".

Le applicazioni con FCE sono molte in quanto consentono di controllare e di verificare il corretto funzionamento delle macchine, ma anche di ricevere o di dare dei segnali di comando per l'espletamento di funzioni meccaniche. Questo sistema è particolarmente utile quando si voglia garantire l'integrità della macchina e/o salvaguardare l'incolumità degli operatori.

The ARIA/OLIO elements can be supplied, on demand, with a travel-end switch "E".

The applications with FCE are many, since they give the opportunity to check and verify the machine correct functioning, but also to receive and give control signals for execution of mechanical functions. This system is particularly useful when the integrity of the machine needs to be guaranteed and/or to protect the workers' safety.



Schema elettrico: / Electrical diagram:



Foto applicazione / Application photos



KIT per tendicatena / KIT for chain tensioner

Pattino in polietilene – Tipo: **VA** / *Polyethylene sliding block – Type: VA*

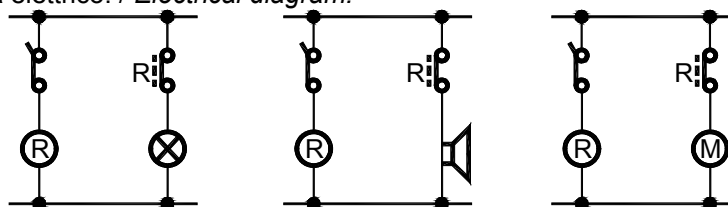
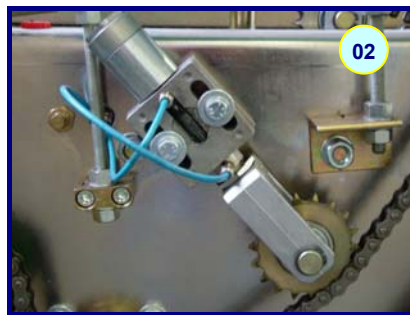
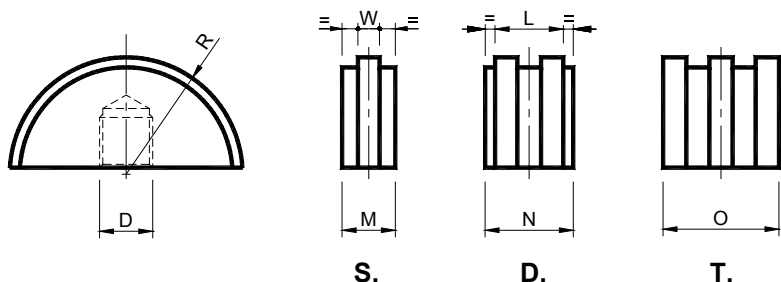

MATERIALI Pattino in polietilene ad alta densità molecolare.
IMPIEGO Profilo semicircolare indicato per piccoli interassi o per montaggi vicino al pignone.
Velocità di lavoro ≤20 m/min.
Temperatura di lavoro ≤70°C.

MATERIALS Sliding block made of polyethylene, high molecular density.
USE Semi-circular profile suitable for reduced interaxis or for installation close to the pinion.
Operating speed ≤20 m/min.
Operating temperature ≤70°C.

Tutti i pattini per taglia “2” e con attacco filettato M10 sono illustrati a pag 49
All the sliding blocks for the size “2” with threaded hole M10 are illustrated at page 49

Per ARIA-OLIO Grandezza 5: / For ARIA-OLIO size 5:

Tipo Type	S Cod. N°	D Cod. N°	T Cod. N°	Catena Chain	R	W	M	N	O	L	D	Peso Weight in kg		
												S.	D.	T.
VA 5-5	OL001127	OL001137	OL001146	1" x 17.02	55	16	25	47	79	47	M16	0.08	0.19	0.31
VA 5-6	OL001128			1"1/4 x 3/4"	55	18	25	/	/	/	M16	0.09		
VA 5-7	OL001129			1"1/2 x 1"	55	24	24	/	/	/	M16	0.12		

KIT per tendicatena / KIT for chain tensioner

Pattino in polietilene – Tipo: **LA** / *PolyethSliding block – Type: LA*

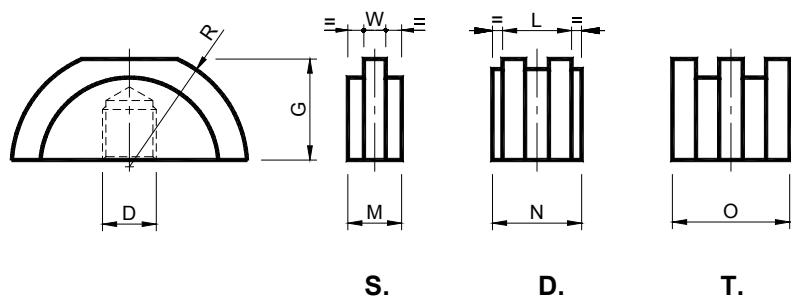

MATERIALI Pattino in polietilene ad alta densità molecolare.
IMPIEGO Profilo semicircolare ribassato indicato per grandi interassi.
Velocità di lavoro ≤20 m/min.
Temperatura di lavoro ≤70°C.

MATERIALS Sliding block made of polyethylene, high molecular density.
USE Semi-circular lowered profile, suitable for large interaxis.
Operating speed ≤20 m/min.
Operating temperature ≤70°C.

Tutti i pattini per taglia “2” e con attacco filettato M10 sono illustrati a pag 50
All the sliding blocks for the size “2” with threaded hole M10 are illustrated at page 50

Per Aria Olio grandezza 5: / For Aria Olio size 5:

Tipo Type	S Cod. N°	D Cod. N°	T Cod. N°	Catena Chain	G	R	W	M	N	O	L	D	Peso Weight in kg		
													S.	D.	T.
LA 5-5	OL001164	OL001174	OL001183	1" x 17.02	46	55	16	25	47	79	47	M16	0.08	0.17	0.30
LA 5-6	OL001165			1"1/4 x 3/4"	46	55	18	25	/	/	/	M16	0.08		
LA 5-7	OL001166			1"1/2 x 1"	46	55	24	24	/	/	/	M16	0.11		

KIT per tendicatena / KIT for chain tensioner

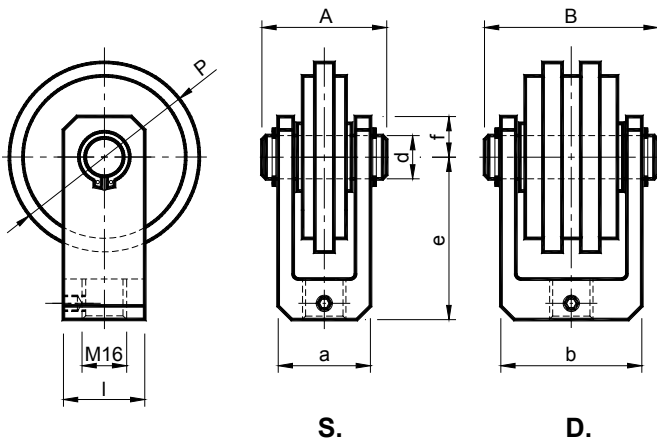
 Rotella in polietilene su forcella – Tipo: **FRA** / Polyethylene wheelset on the fork – Type: **FRA**

MATERIALI Forcella in alluminio o in acciaio.
 Rotella in polietilene ad alta densità molecolare.

Perno in acciaio.

TRATTAMENTI Forcella in alluminio sabbiato o acciaio verniciato.

Perno in acciaio zincato.

IMPIEGO Rotella folla sul perno.

 Velocità di lavoro ≤ 30 m/min.

 Temperatura di lavoro $\leq 70^\circ\text{C}$.

MATERIALS Fork made of aluminium or steel.

Polyethylene wheel, high molecular density. Pin made of steel.

TREATMENTS Fork made of sandblasted aluminium or painted steel.

Pin made of galvanized steel.

USE Idle wheel on the pin.

 Operating speed ≤ 30 m/min.

 Operating temperature $\leq 70^\circ\text{C}$.

Tutte le rotelle su forcella per taglia "2" e con attacco filettato M10 sono illustrate a pag 51
All the wheel on the fork for the size "2" and with threaded hole M10 are illustrated at page 51

Per Aria Olio grandezza 5: / For Aria Olio size 5:

Tipo Type	Cod. N° S.	Cod. N° D.	Catena Chain	a	A	b	B	d	e	f	l	P	Peso Weight in kg	
													S.	D.
FRA 5-5	Δ OL001217	\circ OL001227	1" x 17.02	35	45	67	78	20	77.5	17.5	40	110	0.42	1.17
FRA 5-6	Δ OL001218		1"1/4 x 3/4"	35	45	/	/	20	77.5	17.5	40	110	0.43	
FRA 5-7	\circ OL001219		1"1/2 x 1"	67	78	/	/	20	77.5	17.5	40	110	0.50	

 Δ : Forcella in fusione di alluminio / Fork made of light metal die cast

 \circ : Forcella in acciaio saldato / Fork made of welded steel

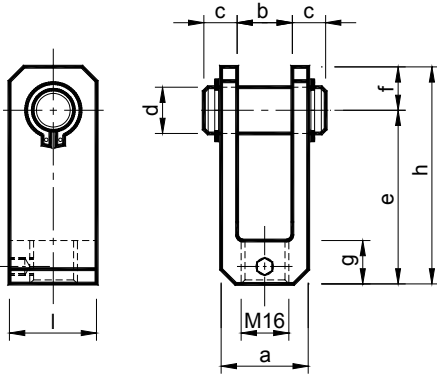
Accessori ARIA OLIO – Tipo: FA / Accessories ARIA OLIO – Type: FA

MATERIALI Forcella F10 / F11 / F12 / F13 / F15: alluminio (Δ)

 Forcella F16 / F17: acciaio (\circ)

Perno in acciaio

TRATTAMENTI Forcella in alluminio sabbiato o acciaio verniciato.

Perno in acciaio zincato.

MATERIALS Fork F10 / F11 / F12 / F13 / F15: aluminium (Δ)

 Fork F16 / F17: steel (\circ)

Pin made of steel

TREATMENTS Fork made of sandblasted aluminium or painted steel.

Pin made of galvanized steel.



Tutti le forcelle per taglia "2" e con attacco filettato M10 sono illustrati a pag 58
All the forks for the size "2" and with threaded hole M10 are illustrated at page 58

Per Aria Olio grandezza 5: / For Aria Olio size 5:

Tipo Type	Cod. N°	a	b	c	d	e	f	G	h	l	Peso Weight in kg
FA 10	Δ OL001196	30	19	10.5	16	60	15	15	75	30	0.14
FA 11	Δ OL001197	35	19	13	16	70	15	15	85	30	0.18
FA 12	Δ OL001198	50	37	11.5	16	60	15	15	75	30	0.19
FA 13	Δ OL001199	55	37	14	16	70	15	15	85	30	0.24
FA 14	\circ OL001200	72	56	14	16	70	15	15	85	35	0.60
FA 15	Δ OL001201	35	19	13	20	77.5	17.5	17.5	95	40	0.28
FA 16	\circ OL001202	67	51	13	20	77.5	17.5	17.5	95	40	0.84
FA 17	\circ OL001203	100	80	15	20	77.5	17.5	17.5	95	40	1.00

KIT per tendicatena / KIT for chain tensioner

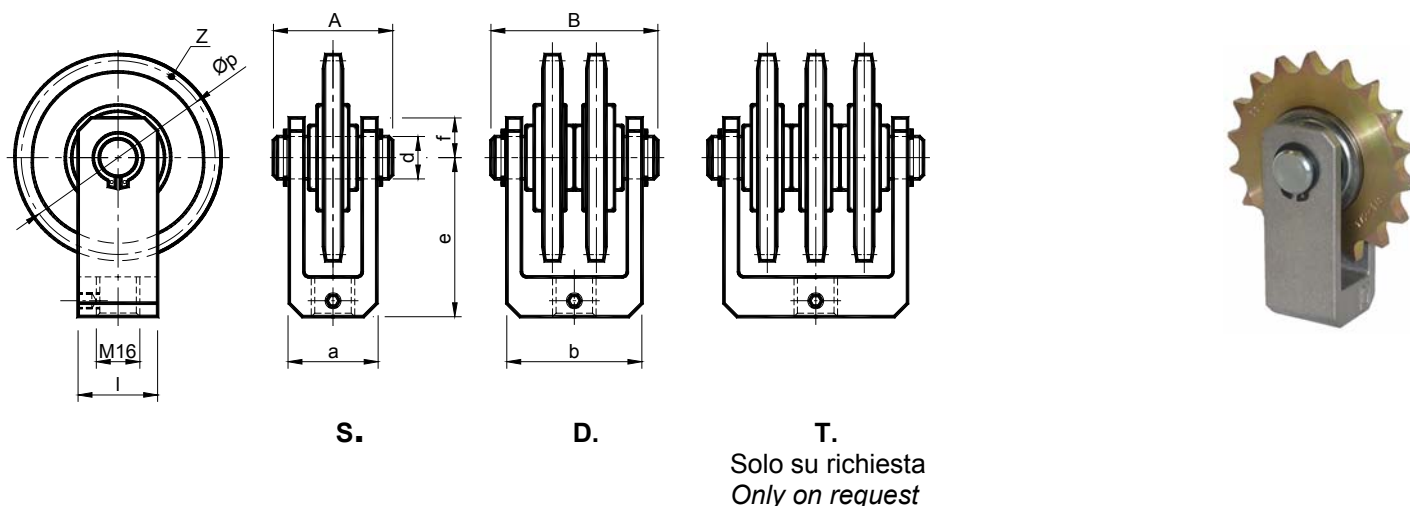
Pignone in acciaio su forcella – Tipo: **RRA** / Sprocket made of steel on the fork – Type: **RRA**



MATERIALI La forcella è normalmente in alluminio, solo per le misure più grandi è in acciaio. Il cuscinetto, la corona dentata e il perno sono in acciaio.

TRATTAMENTI Forcella in alluminio sabbiato o acciaio verniciato. Corona e perno in acciaio zincato.

IMPIEGO Pignone folle su forcella. Il pignone è costituito da una corona in acciaio, montata su cuscinetti con base maggiorata nazionale. A richiesta si possono fornire cuscinetti INA. I kit per catene triple, ASA, metrici o non unificati vengono eseguiti solo su richiesta.
Velocità di lavoro ≤60 m/min.
Temperatura di lavoro ≤100°C.

MATERIALS The fork is usually made of aluminium, only for bigger sizes it is made of steel. The bearing, the toothed crown and the pin are made of steel.

TREATMENTS Fork made of sandblasted aluminium or painted steel. Crown and pin made of galvanized steel.

USE Idle pin on the fork. The sprocket consists of a steel crown, installed on national enlarged bearings.
On demand INA bearings can be supplied.
The KIT for triple chains, ASA, metric or not standard are made only on request.
Operating speed ≤60 m/min.
Operating temperature ≤100°C.

I pignoni tendicatena su forcella per taglia "2" e con attacco filettato M10 sono illustrati a pag 52
All the sprockets on the fork for the size "2" and with treaded hole M10 are illustrated at page 52

Per Aria Olio grandezza 5: / For Aria Olio size 5:

Tipo Type	Cod. N° S.	Cod. N° D.	Catena Chain	a	A	b	B	D	e	f	l	Øp	Z	Peso Weight in kg	
														S.	D.
RRA 5-5	Δ OL001254	○ OL001264	1" x 17.02	35	45	67	78	20	77.5	17.5	40	98.14	12	1.00	2.33
RRA 5-6	○ OL001255	○ OL001265	1"1/4 x 3/4"	40	50	80	88	20	100	25	50	132.65	13	2.90	4.56
RRA 5-7	○ OL001256	○ OL001266	1"1/2 x 1"	50	60	98	110	20	100	25	50	135.21	11	3.30	5.40

Δ: Forcella in fusione di alluminio / Fork made of light metal die cast

○: Forcella in acciaio saldato / Fork made of welded steel

KIT per tendicinghia / KIT for belt-tensioners

Rullo in acciaio su forcella – Tipo: **RAUA** / Rullo in poliammide su forcella – Tipo: **RAPA**
 Roller set in steel on the fork – Type: **RAUA** / Roller set in polyamide on the fork – Type: **RAPA**



RAUA



RAPA

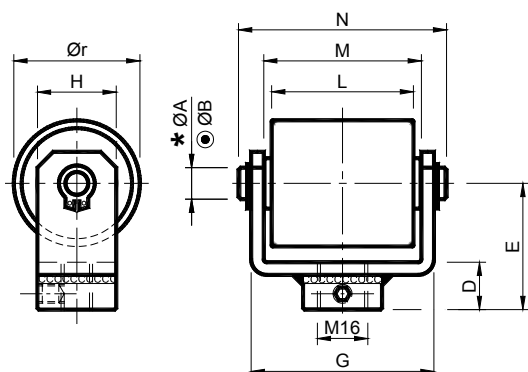

MATERIALI RAUA: Forcella, cuscinetti, perno, distanziali e rullo in acciaio.

RAPA: Forcella, cuscinetti, perno e distanziali in acciaio, rullo in poliammide PA6+MoS nero.

TRATTAMENTI RAUA: Forcella verniciata a forno, particolari metallici in acciaio zincato.

RAPA: Forcella verniciata a forno, particolari metallici in acciaio zincato, rullo tornito 1.6.

IMPIEGO Rullo con cuscinetti ZZ lubrificati.

MATERIALS RAUA: Fork, bearings, pin, spacers, roller made of steel.

RAPA: Fork, bearings, pin, spacers made of steel, roller made of black polyamide PA6+MoS.

TREATMENTS RAUA: Fork oven painted, metallic components made of galvanized steel

RAPA: Fork oven painted, metallic components made of galvanized steel, The roller is turned 1.6.

USE Roller with ZZ greased bearings.

*| ØA : Per rullo in acciaio / For roller made of steel

○ ØB : Per rullo in poliammide / For roller made of polyamide

I rulli su forcella per taglia "2" e con attacco filettato M10 sono illustrati a pag 53

All the srollers on the fork for the size "2" and with treaded hole M10 are illustrated at page 53

Rullo in acciaio Roller set in steel												Rullo in poliammide Roller set in polyamide			
Tipo Type	Cod. N°	*	○	D	E	G	H	L	M	N	Ør	Tipo Type	Cod. N°	Peso Weight in kg	
		ØA	ØB											RAUA	RAPA
RAUA 4-16	OL001640	16	12	15	50	75	35	60	65	85	60	RAPA 4-16	OL001650	1.16	0.65
RAUA 5-16	OL001641	20	20	20	65	111	45	90	95	121.5	80	RAPA 5-16	OL001651	2.98	1.70
RAUA 6-16	OL001642	20	20	20	70	156	45	135	140	167	90	RAPA 6-16	OL001652	5.80	2.49

Campo di lavoro Working field				Campo di lavoro Working field			
Tipo Type	Ø Rullo Roller	Numero di giri max Max rpm	Cuscinetto Bearing	Tipo Type	Ø Rullo Roller	Numero di giri max Max rpm	Cuscinetto Bearing
RAUA 4-16	60	9500	6304	RAPA 4-16	60	6000	6301
RAUA 5-16	80	6500	6306	RAPA 5-16	80	5000	6304
RAUA 6-16	90	6500	6306	RAPA 6-16	90	4500	6304

Il numero di giri descritto in tabella è indicativo. L'applicazione va valutata in base al tipo d'impiego, il fattore di servizio e le condizioni di lavoro.
 The rpm indicated in the chart is approximate. The application must be considered according to the type of use, the service factor and the working conditions.

Accessori pneumatici ARIA / ARIA pneumatic accessories

Cilindro pneumatico
Tipo: CA

Pneumatic cylinder
Type: CA

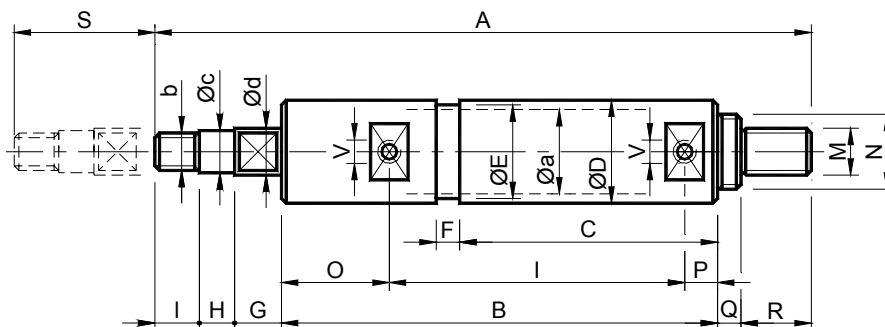

Tipo Type	Cod. N°	t	A	B	C	D	a	b	c	d	E	F	G	H	I	L	M	N	O	P	Q	R	S	V	Newton (0÷6 bar)		Peso Weight in kg
																									Spinta	Tiro	
CA 2-10	OL001005	4x2	135	93	/	22	18	M8	9	10	/	/	10	7.5	61	9.5	M10	/	23	9	/	15	30	M5	0÷150	0÷105	0.14
CA 2-11	OL001006	4x2	150	108	/	22	18	M8	9	10	/	/	10	7.5	76	9.5	M10	/	23	9	/	15	45	M5	0÷150	0÷105	0.21
CA 2-12	OL001007	4x2	200	158	/	22	18	M8	9	10	/	/	10	7.5	126	9.5	M10	/	23	9	/	15	95	M5	0÷150	0÷105	0.45
CA 2-13	OL001008	4x2	250	208	/	22	18	M8	9	10	/	/	10	7.5	176	9.5	M10	/	23	9	/	15	145	M5	0÷150	0÷105	0.68
CA 2-14	OL001009	4x2	300	258	/	22	18	M8	9	10	/	/	10	7.5	226	9.5	M10	/	23	9	/	15	195	M5	0÷150	0÷105	0.91
CA 5-10	OL001015	8x6	229	155	90	49	42	M10	12	16	47	10	15	16	117	15	M16	M28 x1	28	10	8	20	50	1/8"G	0÷830	0÷710	0.73
CA 5-11	OL001016	8x6	279	205	140	49	42	M10	12	16	47	10	15	16	167	15	M16	M28 x1	28	10	8	20	100	1/8"G	0÷830	0÷710	1.05
CA 5-12	OL001017	8x6	329	255	190	49	42	M10	12	16	47	10	15	16	217	15	M16	M28 x1	28	10	8	20	150	1/8"G	0÷830	0÷710	1.36
CA 5-13	OL001018	8x6	379	305	240	49	42	M10	12	16	47	10	15	16	267	15	M16	M28 x1	28	10	8	20	200	1/8"G	0÷830	0÷710	1.67
CA 5-14	OL001019	8x6	429	355	290	49	42	M10	12	16	47	10	15	16	317	15	M16	M28 x1	28	10	8	20	250	1/8"G	0÷830	0÷710	1.98

Accessori Oleodinamici OLIO / OLIO oleodynamical accessories

Cilindro
oleodinamico
Tipo: OL

Oleodynamical
cylinder
Type: OL

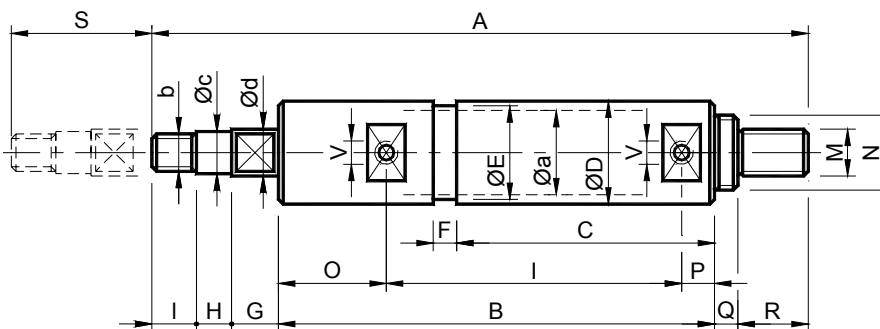

Tipo Type	Cod. N°	t	A	B	C	D	a	b	c	d	E	F	G	H	I	L	M	N	O	P	Q	R	S	V	BAR Max	Newton		Peso Weight in kg
																										Spinta	Tiro	
CO 2-10	OL001020	4x2	140	98	/	22	16	M8	9	10	/	/	10	7.5	65	9.5	M10	/	23	10	/	15	30	M6x1	40	0÷800	0÷490	0.14
CO 2-11	OL001021	4x2	155	113	/	22	16	M8	9	10	/	/	10	7.5	80	9.5	M10	/	23	10	/	15	45	M6x1	40	0÷800	0÷490	0.21
CO 2-12	OL001022	4x2	205	163	/	22	16	M8	9	10	/	/	10	7.5	130	9.5	M10	/	23	10	/	15	95	M6x1	40	0÷800	0÷490	0.45
CO 2-13	OL001023	4x2	255	213	/	22	16	M8	9	10	/	/	10	7.5	180	9.5	M10	/	23	10	/	15	145	M6x1	40	0÷800	0÷490	0.68
CO 2-14	OL001024	4x2	305	263	/	22	16	M8	9	10	/	/	10	7.5	230	9.5	M10	/	23	10	/	15	195	M6x1	40	0÷800	0÷490	0.91
CO 5-10	OL001030	18x6	239	165	100	50	40	M10	12	16	48	10	15	16	120	15	M16	M28 x1	32	13	8	20	50	1/4"G	40	0÷5000	0÷4200	0.73
CO 5-11	OL001031	18x6	289	215	150	50	40	M10	12	16	48	10	15	16	170	15	M16	M28 x1	32	13	8	20	100	1/4"G	40	0÷5000	0÷4200	1.05
CO 5-12	OL001032	18x6	339	265	200	50	40	M10	12	16	48	10	15	16	220	15	M16	M28 x1	32	13	8	20	150	1/4"G	40	0÷5000	0÷4200	1.36
CO 5-13	OL001033	18x6	389	315	250	50	40	M10	12	16	48	10	15	16	270	15	M16	M28 x1	32	13	8	20	200	1/4"G	40	0÷5000	0÷4200	1.67
CO 5-14	OL001034	18x6	439	365	300	50	40	M10	12	16	48	10	15	16	320	15	M16	M28 x1	32	13	8	20	250	1/4"G	40	0÷5000	0÷4200	1.98
CO 22-10	OL001040	12.7x4.8	145	103	/	22	16	M8	9	10	/	/	10	7.5	/	9.5	M10	/	/	13	/	15	30	1/8"G	200	0÷4000	/	0.20
CO 25-10	OL001045	18x6	239	165	100	50	32	M10	12	8	48	10	15	16	120	15	M16	32	32	13	8	20	50	1/4"G	380	0÷30500	0÷20900	0.80

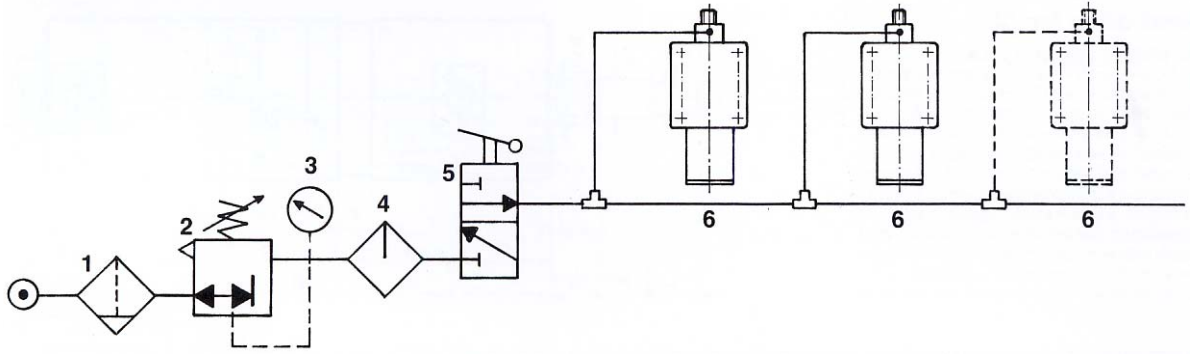
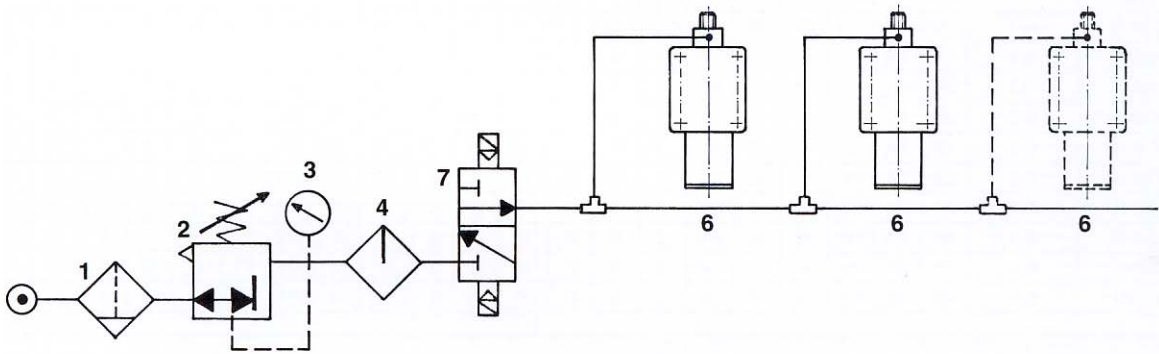
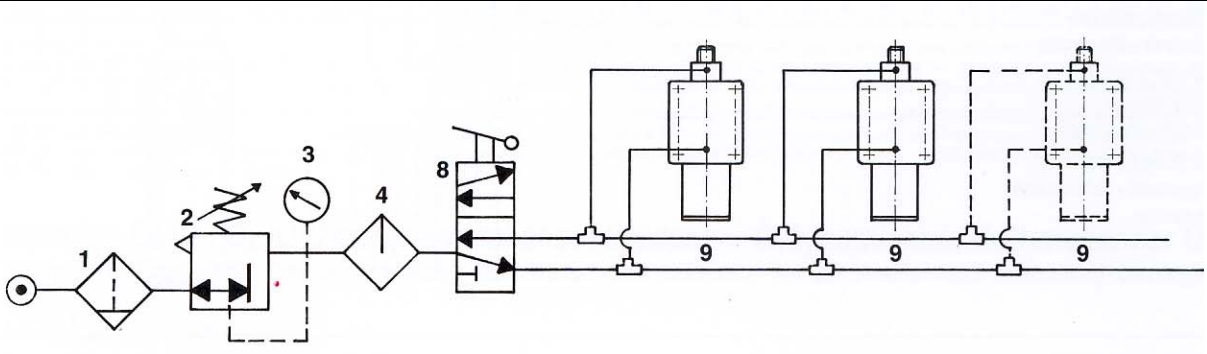
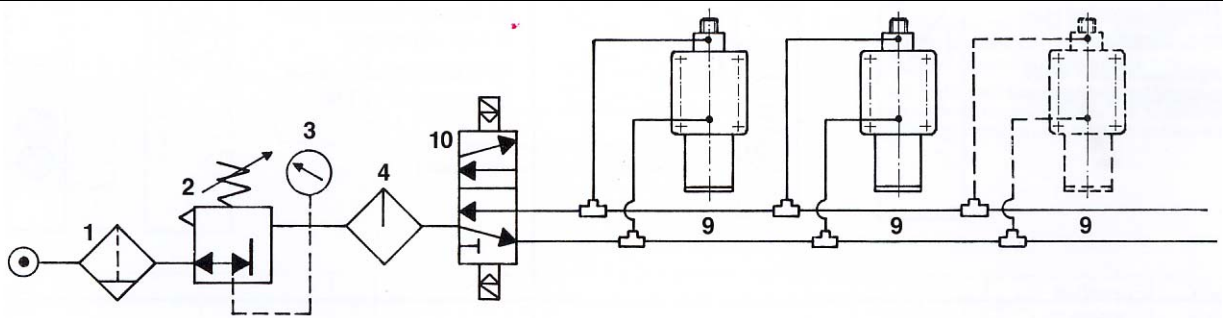
Schemi di funzionamento ARIA / ARIA Operating diagrams
Schema A
Diagram A

Schema B
Diagram B

Schema C
Diagram C

Schema D
Diagram D

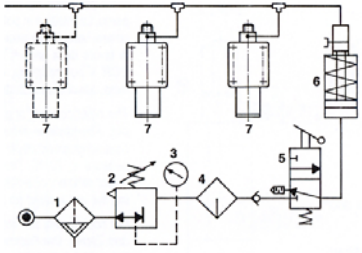
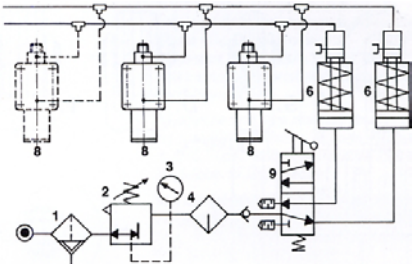
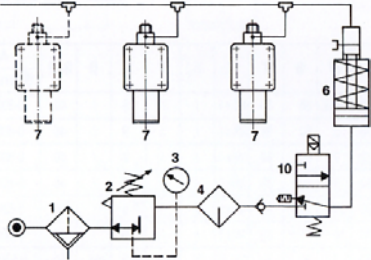
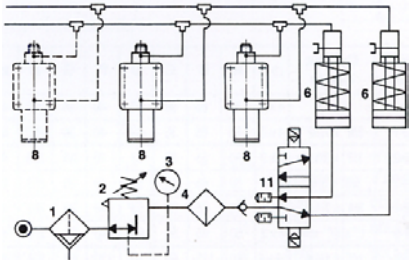
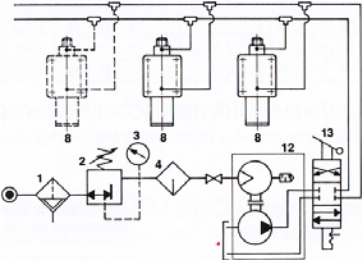
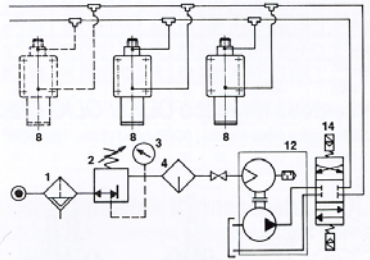
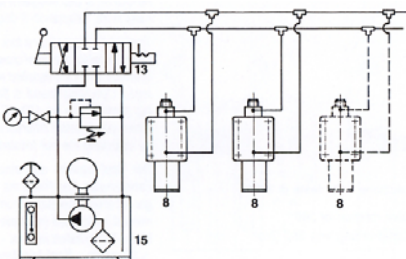
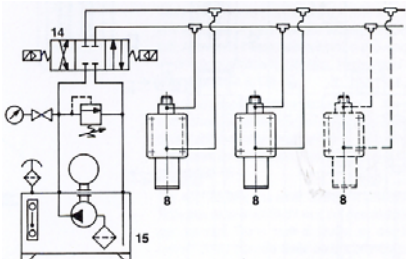
- 1 – Filtro
- 2 – Riduttore di pressione
- 3 – Manometro
- 4 – Lubrificatore
- 5 – Valvola a comando manuale 3/2 (tre vie – due posizioni)
- 6 – Elemento elastico assiale tipo AS (Semplice effetto in spinta)
- 7 – Elettrovalvola a 2 solenoidi 3/2
- 8 – Valvola a comando manuale 5/2
- 9 – Elemento elastico assiale tipo AD (Doppio effetto)
- 10 – Elettrovalvola a 2 solenoidi 5/2

- 1 – Filter
- 2 – Pressure reducer
- 3 – Manometer
- 4 – Lubricator
- 5 – 3/2 Manually controlled valve (3 ways – 2 positions)
- 6 – Axial elastic element, AS version (simple thrust action)
- 7 – 3/2, 2 solenoid electrovalve (3 ways – 2 positions)
- 8 – 5/2 Manually controlled valve
- 9 – Axial elastic element, AD version (double action)
- 10 – 5/2, 2 solenoid electrovalve

Schema di funzionamento OLIO / OLIO Operating diagrams

<p>Schema A Diagram A</p> 	<p>Schema B Diagram B</p> 
<p>Schema C Diagram C</p> 	<p>Schema D Diagram D</p> 
<p>Schema E Diagram E</p> 	<p>Schema F Diagram F</p> 
<p>Schema G Diagram G</p> 	<p>Schema H Diagram H</p> 
<p>1 – Filtro 2 – Riduttore di pressione 3 – Manometro 4 – Lubrificatore 5 – Valvola a comando manuale 3/2 6 – Moltiplicatore di pressione 7 – Elemento di pressione assiale tipo OS (semplice effetto in spinta) 8 – Elemento di pressione assiale tipo OD (doppio effetto) 9 – Valvola a comando manuale 5/2 10 – Elettrovalvola a 1 solenoide 3/2 11 – Elettrovalvola a 2 solenoidi 5/2 12 – Pompa oleopneumatica 13 – Valvola manuale 14 – Elettrovalvola 15 – Minicentralina oleodinamica</p>	<p>1 – Filter 2 – Pressure reducer 3 – Manometer 4 – Lubricator 5 – 3/2 Manually controlled valve (3 ways – 2 positions) 6 – Pressure multiplier 7 – Axial pressure element, OS version (simple thrust action) 8 – Axial pressure element, OD version (double action) 9 – 5/2, Manually controlled valve 10 – 3/2, 1 solenoid electrovalve 11 – 5/2, 2 solenoid electrovalve 12 – Oleopneumatic pump 13 – Manually controlled valve 14 – Electrovalve 15 – Oleodynamical mini-station</p>

Esempi di applicazione ARIA-OLIO / Examples of application ARIA-OLIO

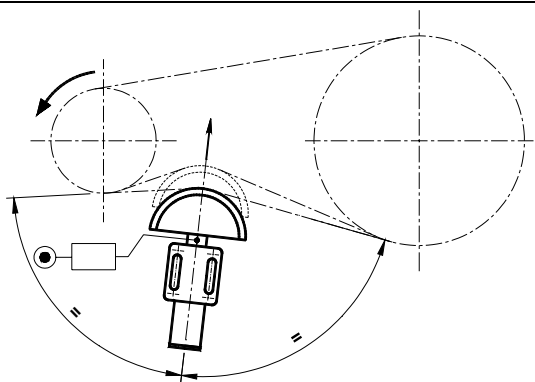

Fig. 1
Tendicatena / Chain tensioner device

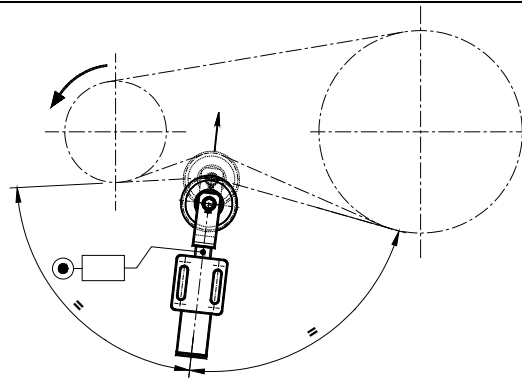

Fig. 2
Tendicatena per alte velocità
Chain tensioner device for high speed

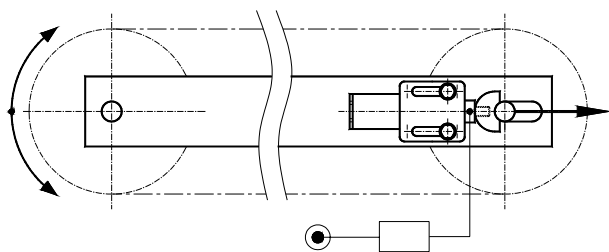

Fig. 3
Recupero automatico a mezzo albero condotto
Automatic take-up via drive shaft

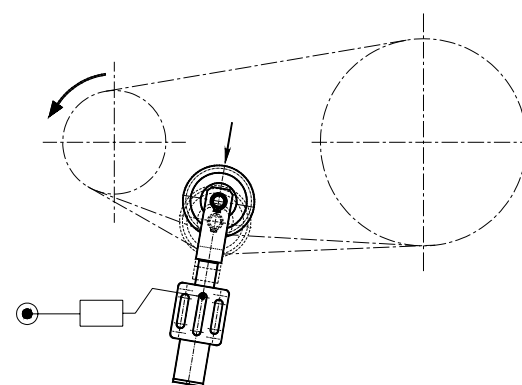

Fig. 4
Tendicatena in tiro
Chain-tensioner in drag conditions

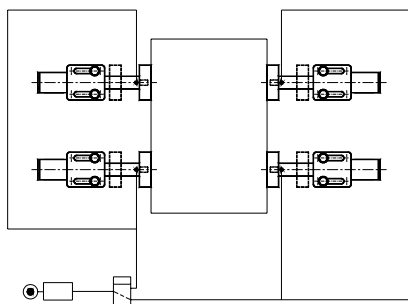

Fig. 5
Gruppi di bloccaggio / Block units

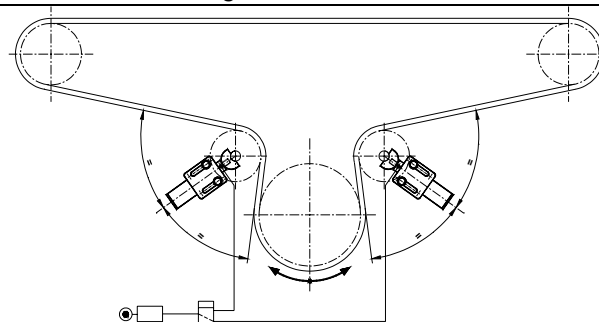

Fig. 6
Doppio gruppo di pressione per trasportatori a nastro o rete
Double pressure unit for conveyor belts or webs

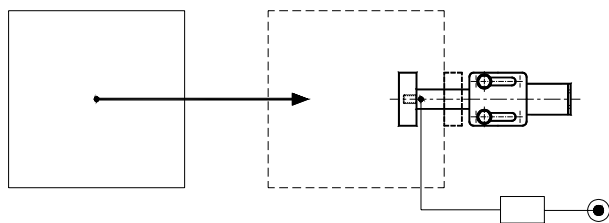

Fig. 7
Deceleratore / Decelerator

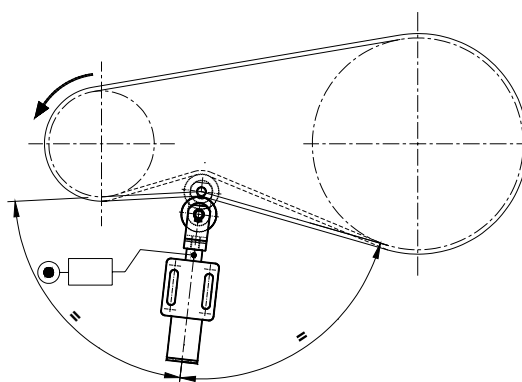

Fig. 8
Tendinghia / Belt tensioner device